

*Cover Art:*  
"Final Project"  
by Ben Tobin

# Spiral



[spiral@oberlin.edu](mailto:spiral@oberlin.edu)

<http://www.oberlin.edu/stupub/spiral/>

**Volume 2, Issue 4**  
**Fall 2009**

# Spiral

*Volume 2, Issue 4*  
*Fall 2009*

An Oberlin College Publication

**H**e whispered in my  
 ear that he's a  
 gypsy  
 and there's magic  
 in his  
 briefcase  
 and i said "can  
 you do that?"  
 and he said "now you've  
 gone and ruined it you can't  
 question  
 magic  
 or else it goes to hell"  
 and i saw the fire  
 in his eyes  
 and knew it was true

by Julia Rosenfeld

## Table of Contents

Letter from the Editor .....	<i>i</i>
The Family Jove: We Only See Each Other at Weddings & Funerals Julieanne Lopresto .....	1
Sandman Emily Wilson .....	15
Sky Kraken Kira Fath .....	18
Wordsmith: A Love Story Emma Conner .....	19
Stormbreaker Kira Fath .....	25
Switchblade: Chapter Two Jeremy Ledgister .....	26
A Naming Emma Conner .....	32
Scenes from the Bizarro 1970s Mike Rauscher .....	33
Shadows (cover art) EJ Landsman .....	46
(story) Edward Allen Underhill .....	47
Contributors List .....	60
Staff List .....	61
Announcements .....	63

---

---

## Letter from the Editor

The members of staff would like to note that the previous issue of *Spiral* (Volume 2, Issue 3) contained several misspellings.

The members of staff would like to extend an apology to Sarah Bolinger, Miranda Fisher, Sara Purvin, and Rachel Sciulli. Sarah Bolinger's and Miranda Fisher's names were misspelled on page 13. Sarah Bolinger's name was also misspelled on the Contributors List on page 66. Sara Purvin and Rachel Sciulli (whose artwork pieces were features on the covers) were uncredited in the Contributors List on page 66.

These mistakes have been corrected for the electronic version of *Spiral* available online.

—**Bryn A. McDonald**  
Editor-in-Chief

spiral@oberlin.edu  
<http://www.oberlin.edu/stupub/spiral/>

---

---

# The Family Jove:

We Only See Each Other at Weddings and Funerals

by Julieanne Lopresto

**S**o,” says Kelsey Davies, “are you in?”  
“Can’t,” replies Billie Jove, her best friend. “Going Upstate for the weekend.”

“Family thing?”

“Yeah.” Billie rolls her eyes. “Kill me now, please.” She slams her locker shut.

Artemisians have longer average lifespans than human beings, but only by a handful of years. This margin gets larger when gifts are factored in; those with the middle name ‘Aceso’ tend to live the longest out of all of them. Hyperaccelerated healing tends to do that to a person.

Death, however, always finds a way in the end, and it was no different for Marchelline Aceso Jove, neé Apollonian, who died at the tender age of one hundred and three in the large house a few miles outside of Albany that she shared with her husband, William.

In the days that had followed, her remains had been brought to the home where she had raised her children, the one now occupied by her daughter, Dahlia, her husband and four children. The six Aphrodines were preparing themselves for the impending wave of family members that would be descending upon them from all across the country.

Marta Aphrodine steps out of the sports car that she had received for her last birthday. She had driven from college (the most expensive one in the country, her mother was always sure to remind people) at her father’s behest. The house that generations of her family members had grown up in unfurled ahead of her. It had hidden and sheltered hundreds of children with strange abilities that could not be shown to most of the world. She fingers the small silver bead that hung from a chain around her neck and considers her last thought proven when she spots a winged boy sitting on one of the eaves of the house, outside his open window. “Simon,” she calls to him, and he stands and steps off the roof in return, golden brown wings catching the air enough to ensure his safe descent.

---

\* This piece is a continuation of a piece begun in Volume 1, Issue 3.2.

Her brother, Simon, was fourteen but small for his age. This had been his first year of schooling that took place outside their mother's kitchen, and he had been mistaken for a seventh grader until Thanksgiving.

"Hi, sis," he says. Simon had been a quiet child, keeping to himself and staying out of the way. He had grown to be a thoughtful and introverted teenager, though he had lost much of the shyness and nervousness that had plagued him as a child. He didn't work well around large groups of people, and with the family assembling around him, having one of the few family members he was close to lying dead in his living room wasn't helping. He had a smile for Marta, though, and says to her, a little louder this time, "Welcome home."

"So who's dead?"

"My grandma."

"Oh." Kelsey raises her eyebrows. "The terrifying one?"

"No," replies Billie. "No, no no. *She'll* be around for another forever. Besides, she's not really my grandma. Just everyone calls her Grandmother. Even my dead grandma."

"So, what is she?"

Billie laughs, but stops short when she realizes she had no idea how to answer that question. "I—I really don't know," she said. And she had never asked. There was something very odd about that—loud, questioning Billie Jove never asking—but it flowed off her mind like water off an oiled surface, just as these inquiring thoughts about Grandmother always did.

"Your family," says Kelsey, "is very strange."

"You're telling me," answers Billie. With promises to talk over the weekend, the two part at the entrance to the park, and Billie walks on surrounded by green.

They begin to arrive that evening, in small familial groups. Parents with rarely only one child—Artemisians are always encouraged to have more than one—and Edward and Dahlia Aphrodine greet them and shuffle them past the body of their deceased relative, assisted by the suitably adorable-yet-grieving twelve year old Marie. Marta and Thad make sure that their relatives are comfortable in either rooms in the house or in the guest house. No one seems to know where Simon has shut himself.

The Aphrodines live in what is akin to Mecca for the Artemisians. The scattered family craves a meeting ground and this, in the state that they are most concentrated in, serves as good as any. Perhaps this fact is what led to these jaded Aphrodine children—they are at just the right place to see that ninety percent of what the Artemisians do as a family is ritual done to keep the loose group of people that is barely a family together.

Marta sighs, and wishes she were back on the campus she considers home. Thad's thoughts are miles away; Marie is still her mother's plaything. Simon, her one hope—the one that has avoided all of this—sits in the tree-house in the copse of trees behind them, breathing and trying not to hear the sounds of cars and faked sorrow.

Her father had named his restaurant the Nightingale—a joke to anyone who knew the family well. Billie, a well-trained product of the Manhattan Private School system, doesn't find it too funny anymore.

She sits at an empty table and orders an ice cream sundae from a waiter who addresses her as 'Ms. Jove'. In record time, her order appears, carried by a short, balding man wearing the white double-breasted jacket of his trade. "Hello, Dad," she says.

"Bill," he responds. "Mind if I join you?"

"That's why I'm here."

Billie knows that her parents had hatched a plan to leave the city while she and her older sister were still young. Then along came Lilith and everything had changed. Luckily, a few months after her birth, they had come into a considerable sum of money (Billie suspected Grandmother's hand in all this), enough to buy a larger house and for Flynn Jove to leave his position as sous chef of a restaurant found in every guide book written in the last ten years about Manhattan to found his own place.

"How are you?" she asks. Billie isn't good with things like this, and, to be perfectly honest, did not feel much at all regarding her grandma's death. Still, she knows her father must be feeling something and, as his child, she feels it is her duty to make sure he's not about to do any of the rash things she'd heard that people were wont to do under the pressures of grief.

"I'm fine, Billie," he responds. "Thank you."

*He knows, she thinks, that I don't feel anything. For her.* She smiles at him and asks, "When are you heading home?"

"In an hour or so."

"I'll wait," she responds, and she does.

Billie has a partition in her closet, with one set of clothes on the right and another on the left. That night, she hangs up her school skirt in the left hand side and pulls a suit down from the right side, leaving it out for the next day.

In the morning, Billie Jove is a boy, woken by the sun in his face. The face that had been *hers* yesterday is a bit wider, a bit squarer in the chin, and his shoulders are broader than his female self's. He smiles at himself in the mirror, runs a hand through his brown hair and leaves his room at last. He is sure to close the door behind him, listening for the click. The doorknob

has a small sun etched in its bronze face; he gives it a tug, just to be sure, and descends to the first floor of the family Jove's townhouse.

In the kitchen, he finds his shirtless father making breakfast. Flynn Jove's blond hair is sleep-tousled, and the white feathers that cover his wings aren't in much better condition. Billie doesn't particularly care if they're late; he doesn't prod his father to move, just sits without a word and closes his eyes, missing the comfort of sleep. He begins to drift off slightly; it is a shrill, familiar voice, stating something about time and lack thereof.

"Don't worry, Daph," says Flynn to his oldest child. "You're mother isn't ready yet, either."

"We have forty-five minutes and you know it," says Billie with a roll of his eyes.

"Where is Mom, anyway?"

Billie shrugs and takes the plate that his father was offering, digging into the scrambled eggs as soon as he sat down.

Flynn begins filling another plate for his oldest child. "In the basement," he stated.

Daphne reluctantly accepts the plate and sullenly chews a piece of bacon from it. "I'm going to get her." Leaving the breakfast behind, she exits the room in a flurry of blonde hair and anxiety.

Billie often assumes that the large stick up his sister's ass originates from the fact that at the age that most young girls pore over proto-romance chapter books set in high schools, Daphne Jove studied the growth charts of pubescent females to make sure she was simulating the correct growth pattern for her age group. There were boxes full of pictures of Daphne's face, taken on the first of each month since she turned eleven, so that she could copy it and change it as she grew older. The perfect blonde hair, just their father, and the green eyes reminiscent of their mother are stolen, not genetically inherited. The rest of her features are cobbled together from other family members, both in and out of her nuclear family.

The quiet of the kitchen is interrupted by the rest of the family trundling in—Daphne leading the procession, followed by Philomele. Behind her mother walked the youngest inhabitant of the household, Lilith Jove. The nine year old youngest child of Phil and Flynn was still dressed in pajamas—she would not be leaving the house this morning. Flynn offers her breakfast—"No thanks," she says. "Just leave some for me and I'll eat some later." Her father pauses for a second; there is always a strange juxtaposition between his respect for his youngest daughter's intelligence—far beyond his own—and his worry for the tiny girl, small for her age. The other members of the family are being shunted out of the room by Daphne. The youngest member of the family Jove watches this display and knows how her father feels.

Lil turns her moon-like face towards her father and smiles broadly. "I'll be fine, Dad."

"Will you be fine?" asks Flynn as soon as he could barely hear Daphne anymore.

Lilith only hesitates for a second. "Yes," she assures him. "Don't be like Mom, okay?"

Flynn smiles. He knows how Phil had been when the subject of Lil being left alone for the weekend had first come up. She had lectured her daughter multiple times on what to do if someone knocked on the door, until Lilith had snapped in her face, telling her she wasn't *stupid*, and that she would not answer it.

Later she had apologized, but Flynn could tell that the girl was frustrated with her surroundings; being such an intelligent child but a prisoner in her own home was not the best combination.

For it was because of Lilith Jove that the family had stayed in what had then been a tiny apartment. Before her birth, they had begun to make plans to move upstate, living close to Edward, Dahlia, and their family. Two children that could change their general appearance at will were a disadvantage to a family living in midtown Manhattan. But then came the day that all Artemisian families face.

Seven months after the family's previous pilgrimage to the home in which Flynn Jove had grown up, they returned, but for an entirely different purpose. Simon Aphrodine holed himself up in his room, Marie clung to her mother more than usual, and even the braver children made themselves scarce. The one they all called Grandmother was coming to visit.

Even though she had seen this ritual performed dozens of times since her youth and, indeed, had been involved in it each previous time she had been pregnant, Philomele couldn't help but feel some apprehension. Her childish fear of Grandmother had followed her into adulthood, and she allowed herself to wonder what the point of all this was. She and Flynn didn't care what power or ability their third child would have; unlike a few family members (she felt) she would love her future daughter even if she was born entirely mundane.

Lying in bed the night before Grandmother's arrival, her husband's arm wrapped around her, she considered. *If I have another*, she thought, *I won't do this again*.

It's a blur in her memory: the wizened hand, crumpled and twitching, touching her distended midsection lightly. A chill runs up her spine in her memory, though perhaps that's from the first time this occurred to her, when she was carrying Daphne. The old woman's faded blue eyes go wide and, as always, she tells the news to Flynn, not to Philomele.

Usually, Grandmother states a name, a middle name to give their

child—Alulus, Hermaphroditus, Aceso—but not this time.

The sun is setting as Grandmother leaves. Philomele feels a kick inside her. She places a hand over the spot where she had felt that foot and feels a need to cover her child already, protecting her from what could be like any mother should. Not even she, endowed with the power to relieve her other children of cuts and bruises, can fix this.

The three Joves that are free to leave the townhouse in daylight begin the slow and steady drive north. Miles away, at their destination, Marta Aphrodine knocks at the door of a room that was once Flynn Jove's.

"Simon," she said. "You'll have to get up sometime."

There's no answer from the small boy inside.

"I brought you some breakfast."

No answer.

She sighs. "You'd better be decent, 'cause I'm going to come in." She waits a second, and then shoves her shoulder into the notoriously reluctant door.

Simon isn't visible at first, until a breeze alerts Marta to the fact that the window is open. A russet-feathered wing is only just within eyeshot from where she's standing. She puts the plate she's been holding down on the nearby desk, and makes her way to the window. "Simon."

"Morning," he says to his sister. "Coming out?"

She bites her bottom lip, and hoists herself up out the window and onto the ledge of roof below. This had been easier when she was a child. She situates herself near her brother, and tries to ignore the lurch in her stomach when a breeze blows her hair into her face and ruffles Simon's feathers.

"How are you?" she asks when she no longer feels like she's going to vomit.

There is no reply for enough time that Marta considers saying something else. "Alright," he responds.

"Liar," she says playfully.

He smiles slightly; she grins back. She pulls a cardboard box out of her pocket. "Do you mind if I smoke?"

He furrows his brow; he hadn't known that she smoked. Instead of saying this, he says "Mom'll kill you if she smells it."

"She won't," Marta replies, and places a cigarette between her lips. She lights it, inhales, and exhales through her nose. The smoke curls around her head. "Are you going to get ready soon?"

Simon shakes his head. "I don't really see the point if I'm not going to go."

She rolls her eyes. "You're not getting out of this, mister. There's a lot of things I'll let you get away with. Sorry to tell you that this isn't one of

them." She turns to meet his gaze and adds in a softer tone, "I know you think you'll feel better if you don't go, but you'll be regretting it for the rest of your life. Whatever you feel now, plus no closure and guilt. That's what these things are for."

"It doesn't feel like it." He isn't looking at her any more.

"What does it feel like, then?"

His shoulders bunch up near his ears and he lets go of a breath he's been holding before he says, "A show. Something that has to be done and no one wants to do. Not something good."

"Huh," his sister says, smoke exiting her body from nose and mouth. She has to phrase this delicately. "Well, you're right. It is. The majority of people here *are* going for that reason. They're—" she waves her hand over the assembled cars before the house "—just here because they have to be."

"I thought I had to go."

"For a different reason, dummy. They're going because it's their family duty; you're going because you'll be a happier, healthier person if you go to a funeral and say goodbye to your grandma."

He tenses; she's hit a nerve by saying it aloud. "Please believe me, Simon," she adds. "You're not like them. Let them do what the hell they like and get what they want out of it and so will you."

There is a long pause in which Simon draws designs on his knee with his finger and Marta refuses to get angry. "Okay," he finally says. His brown eyes meet her gray ones. "You're better at this stuff than Mom. She tried it earlier."

She gives a strained smile and doesn't reply with what she wants to say about their mother. "I think I just gave you an explanation that makes sense to you and she didn't."

He shook his head, and then looks away from her again. "I think you'd be a better mom than she is, sometimes. Whenever you have kids."

Marta scoffs and takes a long drag on the cigarette. "There is no way I am bringing another kid into this clusterfuck of a family." She looks over to her brother, having realized that she's forgotten herself. "Sorry about the language."

The fourteen year old boy shrugs, hiding the fact that he's never heard that word before and that nothing that could be considered a swear has ever passed his lips. He would never admit that, though; looking over at his sister, he sees she's smiling, and he resolves to keep this tiny piece of information to himself, just as he knows she has been doing throughout this conversation.

In the last few years, Marta, who had become his companion in their nuclear family, had grown up and, in some ways, away from him. She no longer lived with them; she was worldly and had mysterious knowledge

about seemingly everything. He avoids those gray eyes which hold everything he simultaneously does and does not want to learn about the falsities in their family's mourning rituals. He knows that once he fully grasps everything that he's been at the edge of knowing since he's been a child, there will be no going back, even to his stunted, half-hermit existence.

He grabs the window's frame with his right hand, and makes the journey inside. She extinguishes her cigarette and follows shortly after.

By the time the Joves arrive, Simon has eaten and showered and is ready for them. Unlike most of the family, the coming of this branch doesn't bother him. His aunt and uncle are among the few family members that don't make him want to crawl in a hole. He greets them and receives a hug from Philomele and a hair-ruffling from Flynn for his trouble, but leaves when other Artemisians begin trickling in to go through the motions of greeting a group they haven't yet seen.

While Billie and Daphne don't agree on everything, one item they can see eye to eye on is their mutual distaste for the majority of their younger cousins. They curl into themselves, pretending to have an in-depth conversation, avoiding the eyes of Rose Artemisa, their first cousin mutual enemy since before they began school. As the daughter of their mother's older brother, it's almost impossible to avoid her for the duration of their stay but "Dammit, we're going to *try*," says Billie.

"Is this a private conversation?" asks an unfamiliar voice. Billie and Daphne turn to the source.

He's a young man, a year or two older than Daphne, college-age or so. His hair is a shade or two lighter than Billie's, but not the startling blonde that indicates a relation to their father's line. His eyes are a bright blue. Daphne furrows her brow. "I'm sorry, but I'm not sure who—"

"Brian. Mars," he add quickly, as if he had forgotten the necessity that last names are when introducing one's self to other family members. There is a foreign air about him, yet his name is familiar. "Daphne and Billie, right? I haven't seen you since we were kids." He knows he needs to elaborate. "I used to live in the city; my parents and I moved when I was eight or so. I guess you'd remember me better, Daphne."

She shakes her head and says "No," quietly, but something flares in the back of Billie's brain.

"You lived downtown," he says. "And visited us. You could go to school before we could."

It's strange to be talking to someone who is both a stranger and an old friend, and even stranger when Billie factors in their relation. They are cousins through the Artemisia line, but are surprisingly distant given how geographically close they once were. They talk of where childhood

took them, and the schools they attend (Brian, now a junior at Middlebury; Daphne, safely at Spence and looking towards the Ivies; and Billie, teetering at Dalton with three years to go before he has to pretend he cares about colleges). Time takes them away, though, and the moment in which the assembled family cares about the Joves passes.

The family is here.

Lilith was born an hour after sunset in an apartment with blacked-out windows, trapping the now slightly larger family Jove in the tiny home that they had been planning on leaving.

The extended Artemisian family is large enough that necessary documentation is easily obtained for members that need them. Billie has almost every piece of paper needed to live an ordinary life in duplicate, switching between male and female; Simon has a letter in his file at school from a 'doctor' stating that he is exempt from physical education and therefore has no need to change clothing in front of other students.

Shortly after she is born, Lilith Jove receives a false diagnosis of xeroderma pigmentosum, a rare genetic disorder. Anyone who was to look at Lilith's medical records could see that her skin lacked the ability to repair after being exposed to UV radiation. Anyone in the family knew it was more severe.

It was something similar to the vampirism or lycanthropy of myth and, in truth, was probably the origin for both those legends. What Lilith had was one of those gifts that had almost entirely dissipated from the family and rarely showed itself anymore. There was something in Lilith's brain that reacted to sunlight; no matter how intelligent and self-controlled the young girl was, in her sun-affected state, there was no telling what she would do.

The stories that existed of those afflicted in the same manner as Lilith stated that a "monstrous transformation" occurred, though it had been generations since one had been given the opportunity to undergo this change. What was known was this: if sunlight touched Lilith's skin, 'Lilith' would recede, and a monster would take her place. While the condition could be easily controlled through blackout shades while Lilith was a newborn, steps would have to be taken as she grew; the family couldn't keep a teenager who couldn't go outside in a two bedroom apartment.

Billie never fully learns how it occurred, though certain family members, Grandmother included, are to be suspected. The Joves found themselves with a sum of money great enough to purchase to a large townhouse on the upper east side of Manhattan. The family moved in the dead of night, and a new existence began.

In the Joves' house, there are mostly blocked out windows from the third floor down. Billie and Daphne's respective rooms have open windows,

but are equipped with blackout shades, just like every other room on the top floor. There are two front doors, one after the other. Go in through the first, close it, then open the second. Neither have windows. The two rooms at the front of the first floor have open windows to create the semblance of normality, but are small and locked to keep the family in the dark. Thus prepared, the family settled in for their slightly stranger existence. Flynn and Philomele agreed that while it would never be the most optimal situation in which to raise a child, it would be better than the alternative in their previous living situation.

Things began to change when Lilith was about ten months old.

Philomele Jove prided herself in having produced two intelligent children, but when her youngest unexpectedly began reading by herself, shortly after learning to speak, she and her husband were stunned. Things progressed predictably, and by the time Lilith turned nine, she could have been entering graduate school. Her parents did everything in their power to make her life more fulfilling and Lilith, being the intelligent child that she was, did everything in her power to make her parents know that they were doing everything right for her.

Still, behind all her intelligence, Lilith Jove is still a child, however much she wants to be an adult. Back in Manhattan, miles away from the goings on upstate, she sits in her room, finally eating the food her father left for her, and tries to forget that she is a nine year old girl home alone, scared of the sun and waiting for her family to return.

The cemetery is behind the Aphrodine's house, far enough away that it cannot be seen from the back yard, but close enough to be within walking distance. Simon is there in body, but only half there in mind—he is still thinking about his conversations this morning, first with his sister, then later with his brother.

"Don't be stupid," Thad had said. "Just because you hate everybody doesn't mean you have to make them hate you."

"What's that supposed to mean?" snapped Simon. He doesn't usually react like that to anyone or anything, but it's Thad and he's not really in the best place mentally at the moment.

"I mean that it's a fucking *dance*. That's why everyone in the family does it. You dance it, you do it, you're considered a 'responsible young man' by the grand high overlords of the Artemisian clan." Thad's brown eyes are slightly narrowed; he's leaning in towards his brother. "You have to do it, too. At least for the reasons Marta told you. The added bonus is that you stay in *her* good graces."

He didn't need to say who he meant. Simon can see her now, sitting surrounded by the upper tiers of the family as the service begins. A fall

breeze touches his mother's perfect hair as she stands proudly next to the one they all call Grandmother.

Simon thinks there is something fundamentally *wrong* with doing something just to put himself in the good graces of the family. His brother, however, had a point. He considered briefly his uncle-by-marriage Collin Artemisia, Philomele's older brother. For having committed the sin of being gay and therefore failing to reproduce, slowly but surely family members turned their back on him. Their other brother, Noah Artemisia, refused to talk to him; the Joves were among the few families that still associated with him, and since it wasn't accepted amongst family members to be supporting him, Simon hadn't seen Collin in five years. Difference was not tolerated amongst the family in which everyone would be considered strange by outsiders.

The dance was continuing to the tune of a dirge. Simon stands between his brother and older sister and knows that these rebellious siblings of his, those who see the dance for what it is, will never escape from it: apathetic Thad will never take the initiative and leave, and will never rise or fall within the family hierarchy. Marta, even with her jaded attitude, will never turn her back on this family. There will be a time, probably quite soon in the future, when she decides that the best thing for her to do is to try and reform the family from within, attempting to abolish the backwards-looking attitude of the upper echelons. But for now, she is here, surrounded by her family, not paying attention to the show they are performing.

Marta has a silver ring that she wears around her right ring finger. When she is bored or nervous, the silver begins to flow like mercury, weaving between her fingers, pooling in the palm of her hand and occasionally solidifying into spirals or whorls, only to flow back to what it had been before—a simple silver ring. During the funeral, it never stops moving. Afterwards, it becomes a thin silver wire, coiled around her smallest finger, bending perfectly and never breaking when she moves her hand. It has settled and stopped for the evening, but in a different shape than it usually is when not in flux.

The family is mingling through the various rooms on the first floor of the house in which she grew up. She is threading through them as the silver had around her fingers earlier. Simon is gone; Thad has half-heartedly sucked up to the adults then vanished off with some cousins his age; Marie would rather go to bed but, as usual, is being carted around by their mother. Marta is by herself.

She decides to sit at one of the tables that have been set in what was usually the house's living room. All of the furniture had been moved to the basement and small tables had been set up for the last evening before ev-

eryone departed. She sees her cousin, Daphne Jove, and nods; the two girls have grown into two very different people than they were as children, but can't help but remember hiding from family reunions with her as a child. Daphne smiles back but can't leave the pestering of two of her great aunts, asking her how she is and how the college search is going. Marta recalls the endless badgering of family members two years previously, and pities her cousin, but still moves on.

Philomele and Flynn Jove are speaking with Laura and Evan Apollonian, probably as they have children of comparable ages who rarely see each other. Of their two children, Eric is off playing with some of the younger children, and Aubrey is back at home, alone, claiming being overloaded by schoolwork. Marta can see her aunt glance away when Eric is brought up; she knows that Phil is considering Lilith, left alone by the parents who do the best to make her life as full as possible.

Wondering where the fifth member of the family Jove is, Marta glances over her shoulder. Billie Jove can be seen wandering towards one of the tables; Marta guesses her cousin's progress, and her eyes land upon Brian Mars, sitting by himself at one of the tables in the room. Brian is set apart, just as he has been from Artemisian gatherings for the past few years. Marta has her own assumptions about Brian's self-imposed exile, but keeps them to herself for his sake and her's. Billie moves towards him, and Marta decides to move on.

Brian Mars raises his eyebrows. "*Billie?*" he asks.

"The one and only," replies the teenage girl before him.

"But you're a—"

She restrains herself from rolling her eyes. "Duh. That's what I do. Didn't you know?"

*Yes*, thinks Brian, *but I've never seen it before. You were a boy all the time when we were kids*. "I just...I guess I just didn't expect it."

Billie shrugs. "I got bored. It's nice being able to change whenever I want to."

"That must be nice," mutters Brian. "That freedom."

Billie raises her eyebrows. "I guess. I never really think about it."

"But during the weekdays? At school?"

"All girl all the time. Boring as all hell." Brian opens his mouth to say something else in reply, but Billie has grown tired of conversation. There has been too much of it today, she thinks with all the gravity and wisdom a fifteen year old can muster. Instead, she says, "Brian", licks her lips and leans closer to her *distant* cousin. "You're not *seeing* anyone at the moment, are you? No girlfriend?"

He snorts and shook his head, saying "No" so quietly it's almost as if he

mouths it.

She raises her eyebrows, taking in this and the reaction he had to her appearance as female, briefly considering her uncle Collin. "*Boy*, then?" He looks up at her, saying nothing. She smiles. There is a moment's silence between them.

She rises to leave, laying a hand on his shoulder briefly. "I'm heading upstairs," she says. "Today is over in my book. Luckily, I managed to wrangle a room to myself from Aunt Dahlia. It's the one at the end of the hall on the left." He turns to look her in the eyes. "You know the one," she continues.

He nods.

A smile. "Wonderful," she says softly. "Goodnight, Brian Mars."

"Goodnight, Billie Jove," he whispers after she leaves. He tells himself he will wait an hour before following her footsteps.

Thad and the other boys return to the house about thirty minutes after Brian Mars finally ascends the stairs. They disperse back to their assigned quarters, and Thad finds his sister tiding the living room slowly and deliberately.

"Hey," he says.

She looks up. "Hey," she responds and goes back to her task.

He watches her for a moment, and then goes to help. "Simon's in bed? What about Marie?"

"Yes for Simon," answers Marta. "As for whether he's asleep or not, I have no idea. Marie, yes. Probably dead to the world."

"Mom pulling the usual shit?"

She nods, and sighs. "I hope she grows up soon," she says. It wasn't an insult, just a hope that her younger sister would soon realize what their mother was doing—using her and keeping her close so she wouldn't become the distant people that her older children had become.

Marta considers her brother, and thinks about how they have grown from children who had once been quite like Marie. She thinks back to the weekend when Flynn and Philomele had come upstate to visit them and, more importantly, to teach Simon to fly. She remembers the argument that her mother and father had after they had left—Simon, who had broken his leg over that weekend and had at that point been missing for the past five hours. It was one of the few arguments she could remember her parents having, and she and Thad had sat and listened as their father accused their mother for having nothing but the desire to move up within the family. She had no empathy for her family, he stated, and that's why, even then, she carted Marie around family engagements and made her youngest child report back on how whichever family member she had been talking to felt

about the conversation.

Their mother had said nothing in reply. Marta and Thad had taken this to heart, and Marta marks this as the moment that she had begun growing into the person that she is today.

She realizes that Thad has said something to her, and is staring at her, waiting for her to say something. "What?" she says.

"Goodnight, Marta," he repeats.

"Goodnight, Thad," she replies. He turns away and walks up the stairs, and his sister shuts off the light and begins to follow.

It is quiet in the car ride back to the city. Philomele gazes out the window, thinking about calling her youngest but never doing more than give the cell phone in her purse the lightest of touches. Her older children—daughters—sit in the backseat, staunchly ignoring each other. Billie, never the type to leave information to herself, considers telling her sister what she has learned about their cousin Brian, about the fact that would lead to disapproving glares from the older Artemisians, the ones who consider it every family member's duty to be fruitful and multiply. She says nothing, though. There is no one she can tell.

For one of the first times in her short life, Billie Jove dwells on the isolation her family suffers and that she suffers for being part of it. It's as if there are four windowless walls around her, even here in the family car, touched by mid-afternoon sunshine. She cannot look out and none can look in to her.

She glances over to her sister, Daphne, the one who goes to a better school and gets better grades, and wonders if she has the same thoughts, the same sense of overwhelming captivity, and shivers slightly despite the heat, still feeling as alone as she always had and had never realized.

## Sandman

by Emily Wilson

My bed's the temple where religion was lost:  
A freshly thawing mattress in place of pews,  
The priest's glass warning spiraled, spoken in frost.  
My most offensive sin was thinking of you.

No nails in palms or thorny crown placed on head,  
Just rivers altering the terrain of cheeks.  
Thoughts of you, excommunicated from bed,  
Confessions we felt too revealing to speak.

The church that worshipped cold, abandoned linen  
Gave no pardon save the action of weeping,  
But at midnight, the demons crawled forth again  
So I prayed to the false idol of sleeping.

"Sandman," my voice echoed pale as rain,  
"I violently long to fall asleep and soon,  
For I have from both love and faith been disclaimed.  
Our lady of mercy dwells not in the moon."

From beneath cracked floor boards emerged the being.  
Shrunken sockets shimmered with glances of death  
As if it were distant lands he was seeing,  
And dust expelled forth with his exhaling breath.

"What is it that you desperately need from me?  
For I have the time to play God for no one.  
A few drugs and drinks and asleep you will be,  
But with this sand business, I have long been done."

"There is only one thing for which I now yearn,"  
I beseeched to the frame in fraying rags draped.  
"My existence is that of a lover scorned  
And sleep seems the bittersweet means of escape."

His teeth were as yellow as his wrinkled flesh,  
 Yet he sighed as if he understood my pain.  
 "I need ingredients to make some sand fresh,  
 But, with journey complete, I'll return again."

The broken floorboards saw his silent retreat.  
 Once more the light in my room shone navy blue,  
 And my sinful mind submitted to defeat  
 Because the emptiness made me think of you.

First he traveled to Atlantic's foamy shore  
 And stood on the porch of the mermaids' lagoon.  
 Recognizing their acquaintance from before,  
 The beastly maidens began to sigh and croon.

Dingy faces draped in smoky blue tresses  
 Spoke as if their syllables were caresses.  
 Hushed words bouncing off copper fish scale dresses,  
 "Forget dear Dusk and swim a while with us."

But Sandman was rendered silent at the name  
 Of the one whose evening gown paints the sky.  
 His heart bathed over in oceanic flames,  
 "No, thank you, ladies, I was just passing by."

Outstretching his palm to touch their oily tails,  
 He extracted his bag with the other hand  
 And pulling from their fins red lobsters and snails,  
 Crushed the snail shells and continued with his plan.

With his crustacean particles freshly ground,  
 Sandman gathered black, deserted bits of earth  
 From whence Cain's cold corpse had long ago been found  
 And mixed sand and blood with greed conceived at birth.

That blood is the origin of all nightmares,  
 The kind that harkens screams from a brother's wrath,  
 The kind that Sandman has always liked to share.  
 He smirked gravely and continued on his path.

And all the while, I read from the Bible  
 Yet found no consolation in faded ink.  
 With no sleep, my only means of survival  
 Was to conjure your image with every blink.

Sandman traveled on worn paths of silver dust  
 That grandfathered metallic mountains ahead  
 Where giants lived igneous rocks of rust  
 And did indeed grind boys' bones to make their bread.

The giant was delighted by his old friend.  
 "Come," he called, "I have just ground up some fresh bone.  
 Some boy and his beanstalk met an awful end!"  
 But Sandman only said, "I must soon be home."

The giant sighed, handing over crushed white stone.  
 "Now I will not press the issue anymore,  
 But I think you will be happier alone."  
 Yet Sandman had already passed through the door.

On a road paved with spiny green cactus flesh  
 And nostalgic tunes sung by violet blooms,  
 Sandman walked towards the woman in night's dark dress  
 While your restless ghost floated in my tiny room.

Sandman, sockets cast down, knocked on Dusk's front door,  
 And she appeared, her perfume the ancient tide  
 Of the rising Red Sea kissing the lost shore.  
 "What do you want? There's no reason for you to linger."

When Eden was more than a four letter lie  
 And before dreaded insomnia kicked in,  
 They chased the red sun as if it plagued the sky;  
 "Together for all eternity to spend..."

Spilling neither consonant nor vowel for her,  
 He placed his bag before her ornate fingers  
 And she leaned back against the frame of her door.  
 "You should just leave. There's no reason to linger."

She sighed and removed dirt from under her nails  
 As into Sandman's bag the particles fell.  
 Dusk lit a cigarette between her fingers pale  
 And when Sandman turned to go whispered, "Farewell."

As I listened to the sermons of my walls,  
 I began to lose hope in the god of sleep.  
 The covers of temptation began to crawl  
 And smothered me, burning into my skin deep.

When from the floorboards, Sandman appeared again,  
 Clutching a full bag of sand in his palm tense.  
 For a few seconds, faith swelled warm from within  
 As I prepared myself for sleep's sweet defense.

But Sandman poured the bag over his own head.  
 "So sorry, kid, but my own lover was lost,"  
 He said, curling up on the floor by my bed.  
 "And being awake is too painful a cost".

At that sound, what was broken did again break.  
 His snores echoed the warnings written in frost:  
 "No love, faith, or hope to be found when awake."  
 My bed's the temple where religion was lost.



## Wordsmith: A Love Story

by Emma Conner

**T**he Wordsmith died on the 20th of June, 18—, precisely at dawn. I remember the date quite well. It was to be my wedding day.

Call me foolish, but I believe I felt it, when he died. Of course I should have been sleeping; it is bad luck for the bride to wake before dawn on her wedding day. But I have never been superstitious, the servants clattered quite loudly in the kitchen below, and—I admit—I was nervous.

Of course I had no reason to be so. Frederick (I suppose then I would have thought of him as Mr. L—) and I had been stepping out together for some months then, and he was as fine a man as ever I could have hoped: kind, handsome, a gentleman. And—well. I loved him.

And yet I was not sleeping. I stood instead there by my window, watching as the stars hid themselves away for the day, and the sky began to lighten.

I remember as I stood I was thinking of the last time we had been together, my Mister L— and I. We had been walking the path by the river, my poor father puffing along some distance behind us. We were strolling amiably, speaking of trivialities, when he tore away from me without warning, rushing past me, around a bend in the path and out of sight.

Concerned, I lifted the hems of my skirts and gave chase. I did not have too far to go—he stood just around the bend, framed by dogwoods shedding snowy petals into his hair. He wasn't laughing, as I expected—he would have thought it was a grand joke, and he was always joking, then. But no, his face was earnest, sincere as the dogwoods, and he caught up my hands in his own as I reached him.

"Darling," he called me, and it was the first time he had used such a form of endearment, "Darling, when we return I intend to ask your father for your hand."

I clutched at his hands for a moment longer, feeling his smooth palms around my own as if I never had before. I thought of all the ways he had

(opposite) Sky Kraken

by Kira Fath

charmed me: his awkward bows when we parted, as if hopelessly uncomfortable with the gesture, the quiet merriment he took in everything, the intent, focused way he sat when I would tell him some story of my day. I tried to speak, but could only manage some incoherent delighted murmur. I suppose you must realize the result—my father consented, of course, as I'd known he would. Not that the knowing had stopped me from pressing my ear to the door as they spoke, anxious for whatever scraps of sound the heavy oak door would relinquish.

It was at this point in my meandering recollections when I felt it. Just as the first orange sliver of sun appeared above the dark hills, I felt it and so I thought perhaps it was the sun that quickened my pulse and sent my head suddenly reeling, that led my shaking hands to search fruitlessly for the stability of the windowsill. Later, when I heard of the Wordsmith's death, I became—and remain—convinced it was him.

But I get ahead of myself. To the matter at hand—it was a fearful feeling, as if the whole of the sky had rushed into my head in one great gust and rushed out again, rifling through the pages of my thoughts and leaving me scattered, dizzy. My mind grasped at the first coherent thought I could find—a memory.

I was very young, and in the Wordsmith's shop for the first time. I was peeking from behind the shelter of my father's legs. He had some trifling little word he needed repaired—he had not even intended to have it fixed until I, for whom the Wordsmith's shop was a place of great wonder, shrouded in the magic of a place forbidden, had begged him into taking me one day when we were about the city on some other errand.

So we went, I clutching fast to his hand in mixed excitement and fear.

The road was bright, snow reflecting sunlight into our pained eyes, so it took a moment once inside for my eyes to take in the shop, and even longer for my racing mind to comprehend. Unlike most of my childhood myths, the Wordsmith's shop lost nothing in reality. It was, as my mother had said countless times as I begged and begged for a visit, noisy and dirty. The one-room shop was dominated by a huge iron furnace, and the rest of the room was filled with all manner of wonderful machines—machines as wide as my parents' big oaken bed, as tiny as my porcelain doll's miniature iron one, and covered in more dials, switches, and gauges than I could count. The Wordsmith had his head inside one of the larger ones of these, its clockwork innards exposed. An assistant sat at the Wordsmith's elbow, handing him tools, and what seemed to me to be countless other workers bustled from machine to machine, checking, tinkering. I thought perhaps it was the most wonderful place I had ever seen.

I was still gaping when the Wordsmith finally turned from his machine to greet us, and I believe I gaped even more when I saw him. He was an old

man even then, but at that time his age seemed to confer no weight to his shoulders, his long white beard was still well-kept, and his wrinkles seemed simply marks of the endless wisdom that he must have within him. I was enchanted.

He began speaking to my father, and though his words did not pierce the fog of wonder that obscured my mind, his voice seemed to convey secrets with every word.

I was not so far lost that I did not watch with interest as the Wordsmith gave my father a glassful of water mixed with a few drops of a dark, smooth liquid he poured carefully from a brown glass bottle. My father drank the concoction with a grimace, and immediately began to cough. This frightened me—my father was often prone to long bouts of racking coughs, but this was a cough of a different sort. This was the cough of a choking man.

But soon it ceased, as my father hacked up the word that, given form by the Wordsmith's medicine, had been caught in his throat.

I stood up on my tiptoes to see the word which rested in the Wordsmith's calloused palm. It was a tiny globe, iridescent. It looked to me as the shell of some poor foolish beetle that neglected to grow a hole with which to poke out head or feet.

But what drew my eye most immediately was not the delicate shimmering word itself but the rough gash down the middle, the colors, endlessly shifting everywhere else dulled to an angry grey around the edges.

The Wordsmith noticed my interest, held it down, smiling, so I could see.

"Can we fix it, do you think?" he asked me, voice serious.

I knew the answer. "Yes," I said. "You just need to make the colors move again."

I don't know if he was surprised—he must have been, I suppose, but I only saw the smile break out on his face as he said, "Exactly right, child. And how shall we accomplish this?"

Again I found I knew the answer. "You need to separate them. The colors. They've got all muddled together so you can't tell one from the other."

Later I would learn that each color was a meaning, and they were mixed up occasionally, making this particular grey hue, that precisely shaped break. Then I just knew that the Wordsmith nodded gravely and took me to one of the great machines, showed me where to place the word, how to set the gears and dials on the front, let me help him turn the great cranks to open the pipe from the great furnace to let steam into the engine. The machine began to hum and click and the Wordsmith left me then to watch through the little glass window as the grey seemed to tremble, then shake itself apart until finally the colors streaked free, knitting the gash closed and leaving the sphere perfect, healed.

My father had been standing uneasily by the door the whole time, and when the machine whirred to a stop he hurried over, collected the word and me, and hurried out into the bright sun.

I became aware, suddenly, that the sunlight was not just in my memory but shining in through the window I stood at. I was not yet late but it was well past the time when I had planned on waking; I hastily called servants to me, hurried through preparations, hurried downstairs.

Of course I was happy. I do not lie when I say that I think perhaps I have never been so happy, not before, and especially not since. And yet all through the ceremony I looked for the Wordsmith. My parents would never have approved him being there, but he had promised on my urging that he would sneak in. I could not bear the thought of him not being there, not when he had been there for so long.

After that first visit I was forbidden to go back unsupervised; my father saw the love in my eyes that day and, perhaps rightly, feared it. And of course I snuck back anyway, whenever my nurse took her eye off me for long enough. The Wordsmith taught me many things. He showed me each problem way a word might break, the workings of each machine needed to fix it. I delighted in those visits, the dainty little words, the smooth great machines, the pride and thrill when I made a broken thing whole again. But as I grew older, the visits grew fewer and fewer. My father, I believe, suspected, and endeavored to keep me from it; he set servants about to watch me, took me to the Wordsmith's shop when I had broken a word himself. While he was there each time he would ask the Wordsmith when he would take an apprentice and the Wordsmith would reply each time that he had not yet found a suitable boy with the gift for it. The exchange took on an air of ritual, and so I could force myself not to worry over its meaning.

It was after the wedding, while I lingered by the door, hoping that the Wordsmith would appear, that I lost the first word. Frederick noticed how I sought around, and questioned me about it for some time. At first I was reluctant, tried to wave it off and smile, and yet Frederick was not convinced. Frederick alone knew of my childhood hours with the Wordsmith, and yet...

I tried to tell him, finally. "The Wordsmith," I said. "He p—" I felt the shattering in my throat, a feeling still, at that point, unfamiliar. "He p—" I tried again, then turned away, muttered "He said he would come."

I lost the second word three weeks later. I'd found out about the Wordsmith's death not two hours after the wedding, when I went to have the word fixed and also, I half hoped, to find some reason why he hadn't been there. The panicked assistants crowded around me as soon as I walked through the door. The Wordsmith was dead, and there was none to replace him.

This was not the reason I had hoped to find.

I wonder, often, what would have happened if I had been brave, then, and fixed the word myself. But I did not. I turned, shocked, and walked from the shop.

Since then Frederick had accused me first of being melancholy, then, finally, of sulking. Perhaps he was right, but I could not help but feel the weight of grief every time I tried to promise something and could not. We fought that night for the first time; I accused him of being unfeeling, he called me hysterical, we both lost hold of our emotions and screamed late into the night. In the morning I still felt petulant, wronged, but tried to apologize without much feeling, and the word "sorry" warped and twisted in my mouth, knotted itself up until it meant something almost the opposite. Frederick too lost that word that day, and afterwards whenever we would apologize it seemed like accusation.

Other words followed, little ones, warped by misunderstanding, words that we had used for stand-ins strained too far under the weight of meanings not their own.

There were moments, still, when I loved him; when he left me strange gifts throughout the house, an extravagantly ugly carved wooden fish in the empty bathtub, a sopping bouquet of paper flowers hanging limply from my water jug, the so that I might smile throughout the day; when he found some phrase in some book that he found pleasing, and would repeat over and over again throughout the day, his smile never dimming. But as the words we couldn't say piled higher and higher between us, those moments became fewer and fewer.

It took a year for me to lose every word. We were yelling, each in our own private languages—we yelled so often then, as though the heat of our voices could melt together the cracks in our words, mold them back into their proper shape. I do not even recall what the word was—only that I hurled it at him along with some insult he did not understand, and it shattered as I did. From then on we grew silent, no longer babbling at each other, no longer looking at each other.

I had taken to long, rambling strolls throughout the countryside, all-day walks in which I tried only to get as far from our miserable house as possible. Often I found myself retracing paths I had taken with Frederick and, unable to bear the sharp rush of memory, I turned my walks to the city. At the time it seemed merely an extension of my own suffering, but it seems to me now that things were in shambles everywhere: the streets were silent, or filled with angry shouting; shops were closed, doors barred, windows shut. It took me one month further before I realized the closed door I had come to was Wordsmith's shop. Hesitantly I tried the door.

It wasn't locked but it fought against turning, so long shut had it been.

I didn't know quite why but I forced the door open and walked into the dusty shop.

I found what I was looking for immediately: the dark brown bottle, sitting where it always was on a windowsill. I had no water so I measured out a few drops into my mouth directly, ignoring the thick, oily taste. I felt the legions and legions of broken, misused words harden inside me, and I coughed and I coughed and I coughed, spewing forth ten or twelve words with each one. When finally it was over I sat surrounded by a gleaming ocean of words, throat aching, gasping for breath, and utterly, utterly exhausted. I fell asleep, then, there on the floor.

When I awoke night had fallen. Would Frederick worry? I wasn't sure. But something wouldn't let me leave, so instead I lit a fire in the furnace and set the machines to running like he had taught me, oiling those that had rusted, setting broken parts to right. When finally every disused machine was working once more, I chose a word from the pile, and began working.

It was twisted and cracked more than any word I had ever seen before, and it took me almost a day of toil to give it nearly the shape it had before. Still it was not perfectly spherical but I was tired, impatient, out of practice, so I put it in my mouth and let it dissolve on my tongue.

I had forgotten the warmth of an unbroken word inside of me, the feeling of speaking without shards of the words sticking in my throat. I spoke the word outside, once, twice, and it tasted of honey, sweet and golden. I felt the truth of it inside me, and it compelled me out of the shop, drove me at an almost-run all the way home. I found Frederick with a chair dragged up to the front door, peering out, let him catch me up in his arms as I walked in.

"Darling," I called him, and it came out lopsided and tilting, rough and unused. But "Darling," I said again, and he understood.

*Storm Breaker* (opposite)  
by Kira Fath



Chapter Two



by Jeremy Ledgister





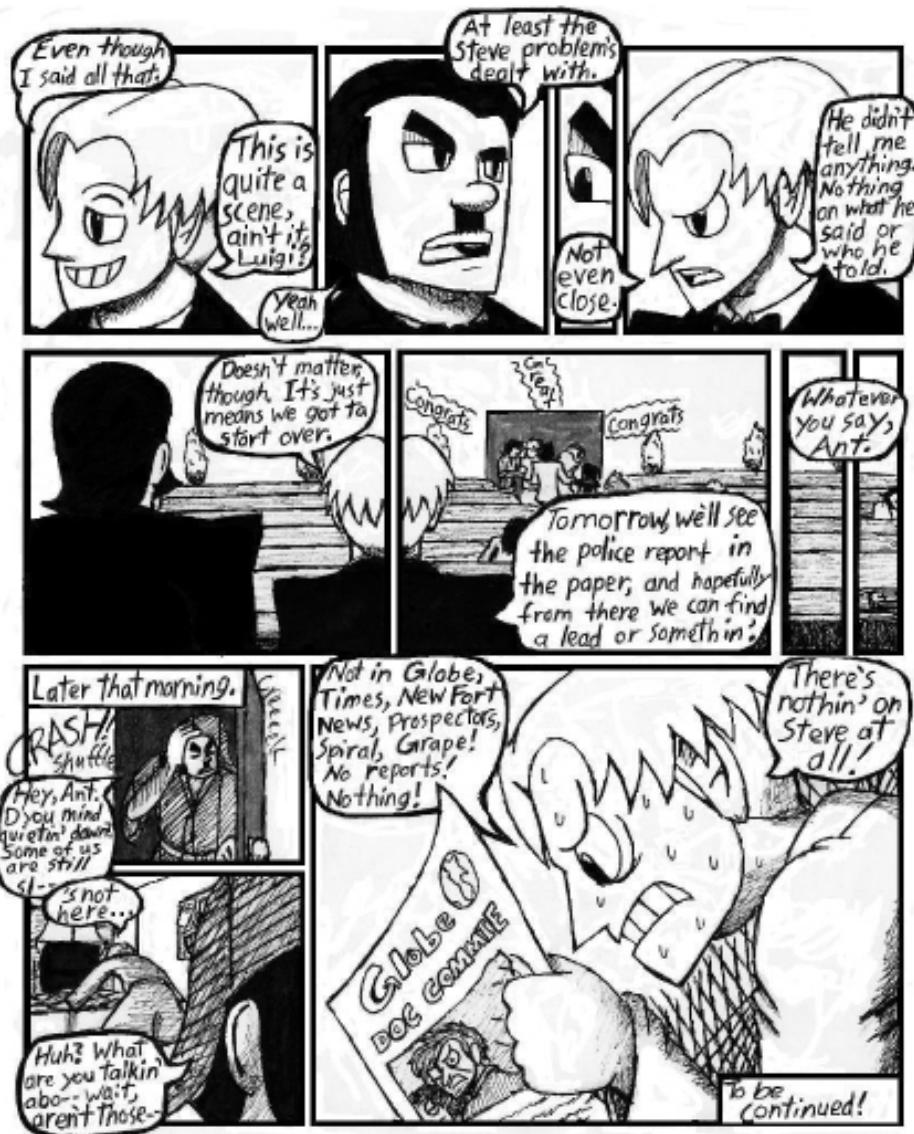

## A Naming

by Emma Conner

I stomp my right foot, and it sinks  
through the floor. The earth  
trembles beneath me, around me.

I am possessor  
of a hundred thousand names.  
They flit far beyond me,  
lovely and terrible,  
on wings of glass.  
*Funny little man*, most call me,  
and I am safe.  
Rumpelstiltskin, said this one,  
and the name flew at me,  
pinned itself large against my chest.

I clutch my left foot in my right hand  
and the fabric of me  
begins to split up the middle,  
the threads I have spun up  
so carefully,  
all flax and gold and hope,  
fray, and I am loose, tender.  
A tug, and there will be nothing left of me.

I tremble like the earth.  
Nothing left of me but names.

## Scenes from the Bizarro 1970s

by Mike Rauscher

**I**n two weeks, I will be honored before the party congress for how my atomic rocket thrusters promise to grossly simplify the logistics of manned military spaceflight and enable the rapid proliferation of Soviet space infrastructure in the face of the imperialist conquest of the moon. I will be the only man in the whole room not clapping as I accept my award, walk to the podium and give a speech in the expected humility of an engineer about the power of man and the wonders of Soviet science to be forgotten over lunch.

Posters of Lenin will tower over the same square where not so long ago the parades would cart about the same R-6 rocket that started this whole mess. The rocket that flew Sputnik into space and put comrade Titov around the world while the world worried. The rocket whose tears burned to harmless ash, whose promises burned slowly. But then the stars were still silent and the moon still belonged to nobody. Saigon still stood and the world still laughed at jokes.

The rocket grew up. We all grew up.

How I want to tell them that the Americans had already dug their own graves in Saigon. That every Soyuz fighter and Almaz strategic re-entry platform and every Zenit spy satellite overheard only lends more hands to help digging them out. How I want to tell them, pointing out to Lenin's grave, the shame and scorn he would feel seeing trains moving propellants and reactors instead of Soviet citizens and the full brunt of electrical systems powering telemetry stations instead of streetlamps. His outrage at the billions of rubles spent year after year so that we may demolish everything we have built at the throw of a switch while our cities crumble and our people go hungry.

How I want to tell them.

-Personal notes, Valentin Glushko

There's a curiosity to nuclear weapons and the fears of the atomic age unlike that of any of the technological wonders that have come of this century, even this decade. Here as I type this from my office on the moon. Think of that. All of this made possible by all manner of machinery of whose inner workings I am dreadfully ignorant, each of which is an astounding work of engineering in its own right, every bit the puzzle and challenge of the mundane atomic bomb. But even I can contemplate seeing the world through my window every night before bed better than a man can fit inside his head the sheerly impossible scale of violence these weapons make possible.

They are our thunder gods and our superstitions, our physicists and chemists their priesthood, grainy stock films and news clippings and photographs their iconography. All mere shadows of a terrible wrath upon anyone and everyone on the Earth as it passes unflinching and unchanging through my tiny office window. Were the world to light fire right now the stock footage and news clippings and photographs would still be the only things I would be able to conceive of, a cardboard city skyline against a cartoon mushroom cloud.

But it is 1975, and the world is still there, and the men outside in the hallway are still digging holes in the moon, planting gunmetal flowers with atomic blossoms towards the Earth. It's been thirty years since Hiroshima, and we are still listening to the whispers of titans.

-Anonymous diary clipping, dated 4/7/75, Horizon Station mess hall bulletin board.

---



---

## OFFICERS' GUIDE TO SOVIET STRATEGIC ROCKET FORCES - p5

though division into the polar-orbit defense-band paradigm has mitigated escort requirements for Almaz platforms, as each Almaz can rely on two contraorbital fighter-bands for mutual protection.

### Soyuz Fighters

The highly adaptable Soyuz spacecraft has formed the basis of the Soviet strategic rocket forces manned interceptor corps, ferrying crew and supplies among the Almaz defense platforms, protecting Soviet interests in low Earth orbit and remaining on constant alert against American missile attack from the moon. These are the two common fighter variants—the Soyuz VI-P low Earth orbit fighter and the Soyuz LKP heavy lunar interceptor.

### Soyuz VI-P

The Soyuz VI-P fighter (Figure 1) is built largely unmodified from the basic civilian Soyuz-A platform, with headlight-shaped re-entry capsule, aft-mounted maneuvering module and equipment module, and forward pressurized orbital module to provide for crew living space and mounting points for the Igla automated docking system and mission-specific equipment.

The basic modifications for the Soyuz VI-P are the replacement of the side-by-side seating of the two-man crew in favor of tandem seating to facilitate ejector seats, a short-range target-acquisition radar, and the removal of the paired solar arrays. Characterized by large radar cross-section and the necessitation that the spacecraft be oriented towards the sun, the solar arrays are replaced with four large radioisotope thermoelectric generators. The RTGs are carried into orbit outside of the Soyuz launch shroud, and return under their own re-entry and recovery system for re-use. The Soyuz VI-P features the common combat orbital module, with Igla automated docking system plumbed for re-fueling at Almaz strategic defense platforms and a 23mm Nudelman autocannon with 150 rounds and is armed with six semi-active-radar homing versions of the K-13 air-to-air-missile adapted for the anti-satellite and anti-fighter role.

The two-man crew spends an average of three weeks on patrol in orbits sweeping the globe, with staggered sleep and work shifts such that no

spacecraft spends more than four hours off-duty and is never more than a minute from full-alert. In the event of a full nuclear exchange, the Soyuz VI-P provides for immediate Soviet response capability against American missile attack and Mercury silo-based space interceptors. Crews are rotated after four re-supplies at Almaz stations, and the crew spends the remainder of their tour of duty on board the Almaz.

Figure 1: Soyuz VI-P Fighter

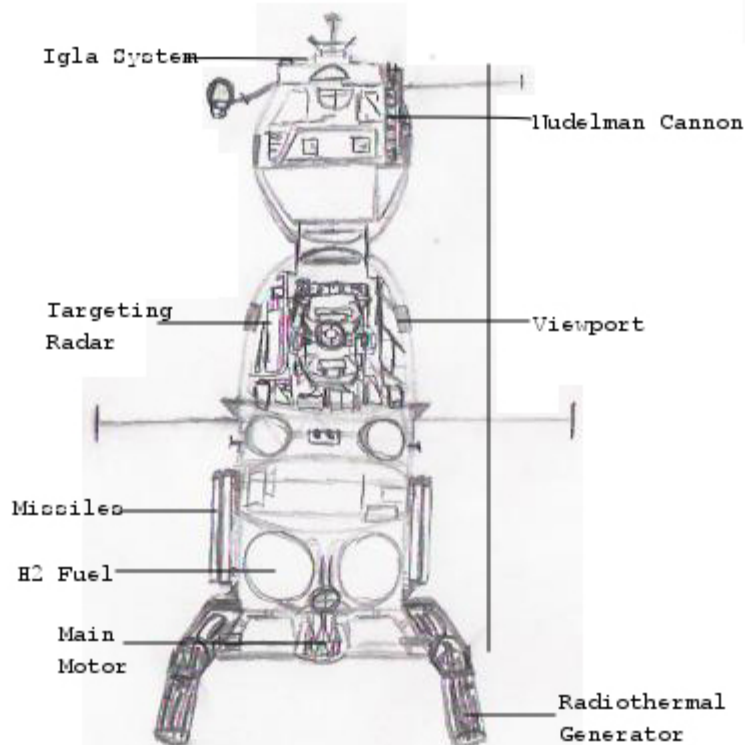

## Soyuz LKP

The Soyuz LKP (Figure 2) lunar interceptor represents one of the more extreme developments of the basic Soyuz arrangement, featuring a single-seat, radiation shielded, heavily-laden re-entry module, a completely redesigned equipment module featuring RD-010 nuclear thermal engine with large dihydrogen monopropellant tank, and large passive sensor array boom. The Soyuz LKP retains the basic combat orbital module shared from the VI-P Soyuz with Igla docking system and 23mm Nudelman gun. Despite its radical differences, the Soyuz LKP interceptor maintains overall a high commonality of basic systems with other Soyuz in terms of orbital maneuvering reaction control systems and target acquisition systems and electronics.

Figure 2: Soyuz LKP Heavy Interceptor

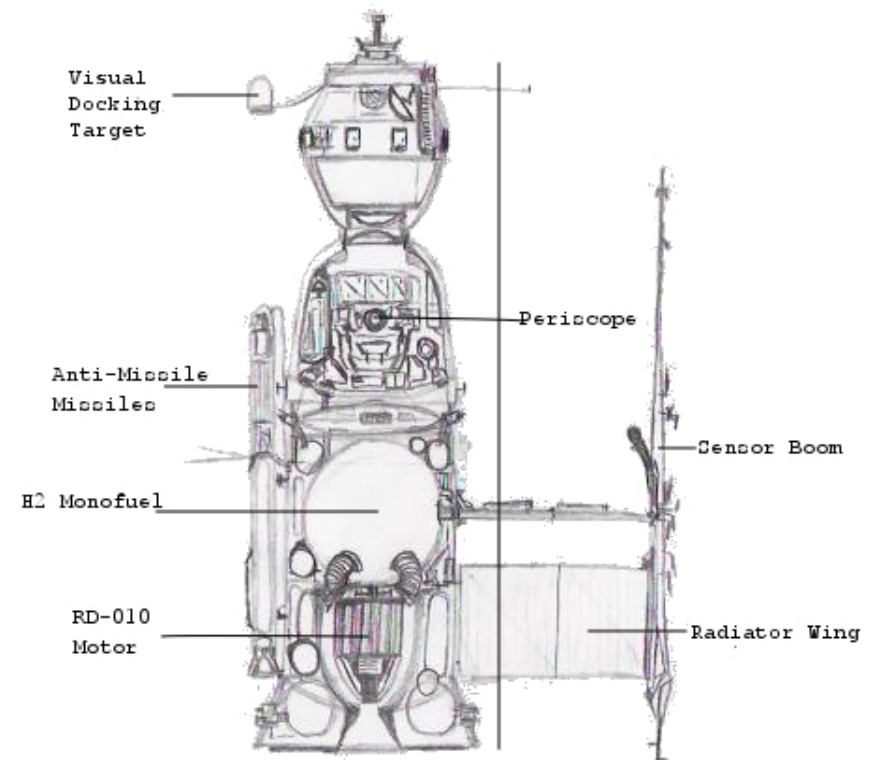

This variant is sometimes referred to as a "Molniya Soyuz" after its orbit, itself named for a communication satellite system with a highly-eccentric, twelve hour orbit which swings deep into the high-energy Van Allen radiation belts around the Earth. This, along with the nuclear engine, necessitates the heavy shielding to avoid chronic levels of radiation exposure for the single crew member. Typical of OKB-1 Korolev-designs, A boom-mounted fueling system helps to preserve the integrity of the radiation shielding between the re-entry and equipment modules.

Soyuz LKP orbits are typical Molniya 12-hour orbits, arranged so the peak of the orbital period is over Soviet Territory. The high apogee-dwell with this orbit allows for maximum time in friendly territory in the event of a full nuclear exchange. Where the current American MAD strategy is presumed to center on the use of nuclear missiles based on the moon to ensure overwhelming response no matter what happens to American strategic nuclear forces on Earth. The Soyuz LKP mission profile holds the craft at apogee with the firing of its RD-010 nuclear motor to enter a large circular orbit where it may outlast the nuclear exchange. Once four American Translunar Ballistic Missiles come into range, the Soyuz LKP then fires its paired interceptor rockets. Each rocket splits into a kinetic energy impactor cloud for engaging the first target missile while the engine block and second warhead continue for a powered final interception of the second target missile. In addition to the orbital module's 23mm recoilless gun, The LKP spacecraft is also equipped with a pair of Vympel OKB K-13 short-range missiles for self-defense.

The single Soyuz LKP crewman serves an entire tour of duty in orbit and remains on alert for every second set of the eight hours at the peak of his orbit, sleeping through the second set and maintaining radio silence throughout, barring encrypted telefax communications of target information and failsafe orders. After six tours of duty, each resupplied and refueled at an Almaz defense station, the nuclear motor is fired to place the jettisoned equipment module into its nuclear waste storage orbit.

## RESOLVED

That for inclusion in the five-year plan of 1965-1970 the Supreme Soviet authorizes the following high-profile military and civilian space projects.

-Head Designer Chelomei and OKB-52 are to complete UR-500 launch vehicle and orbit Almaz piloted strategic applications test platform no later than final quarter 1967 and demonstrate nuclear-armed re-entry vehicle capability for VVS and Strategic Rocket Forces.

-Head Designer Korolev's Soyuz-P space interceptor program is to be managed personally by OKB-1, with test article capable of anti-satellite operations as outlined by VVS no later than first-quarter 1967 and prepare for mass deployment in orbital defensive system.

-Head Engineer Glushko is to lead development of compact nuclear-thermal rocket motor for spacecraft propulsion and logistical applications. Any submitted design must match or exceed efficiency and reliability of existing chemical rockets

-Cancellation of L1 and L3 manned lunar program and associated booster development, with imminent American circumlunar flight. Cosmonaut Training groups already selected should be given top assignments in Almaz program.

-Planetary probes missions to Mars and Venus will be allocated three launches per year with mission priority entirely within discretion of ministry of sciences

-Orbiting of full Molniya Military/Civilian communications constellation for servicing of the entire geographic expanse of the USSR

*You can read that all you want, Sergei, that's straight from the top. The VVS is catching on to you. You can't sell them weapons and then use their money on your toys. What are you trying for Sergei? Science? Propaganda? The first man in space was American. The first man on the moon will be an American. This isn't a game. Don't think for a moment these aren't the same Americans as ten years ago.*

*OKB-1 Had better start shaping up or our friends in the Kremlin will start getting a different story from me. I like you Sergei. You do good work, and you've been through a lot for it. But priorities. Have the fighter up in time and I'll see what I can do for civilian manned station work but by all means have the fighter up in time.*

My Best

Dmitri Ustinov, Soviet Military Air Forces

## OVERVIEW OF UNITED STATES STRATEGIC SPACE CAPABILITIES

This document is intended to familiarize the reader with the basic capabilities of some of the various spacecraft employed by the United States Air Force, with a focus on spacecraft suited to the logistics or fighter-interception. This article is not intended as a technical operations manual, though drawings include fuel and power arrangements.

### MERCURY II SILO-BASED INTERCEPTORS

The Mercury II interceptor (Figure 1), directly derived of the original Mercury space-exploration capsule, provides for point-defense of American

Figure 1: Mercury II Interceptor System

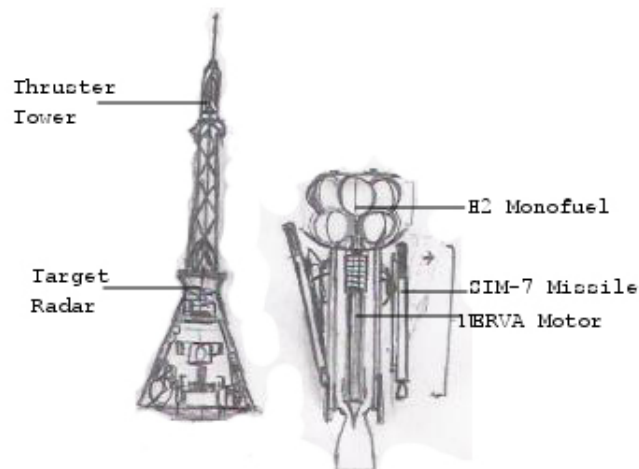

space interests and immediate response capability to threats in low-Earth orbit, various high orbits, and lunar sites at Von Braun Station and the Horizon lunar missile command center. Optimized for compactness and rapid deployment at virtually un-

modified Atlas Missile silos, the Mercury II fighter presents the lightest manned spacecraft to date capable of lunar-transit. This optimization comes at the price of a rigid support infrastructure, and the interceptors' future is uncertain with the continuing retirement of Atlas ICBM hardware in favor of Titan and Minuteman ICBM systems. This, along with its cramped cockpit, stressful mission profile, lack of all but the most primitive docking adaptor and expensive single-use nuclear motor have led the US Air Force to phase out the interceptor into the 1980s in favor of the equipment commonality, modularity, and versatility provided by Gemini-based hardware.

Given the narrow payload margins of the launch hardware, weight-savings are sought in the design wherever possible. The Mercury II capsule

eschews all non-essential equipment from the basic exploration program capsule in favor of combat avionics and radar systems. This is facilitated through the deletion of the observation periscope and the replacement of the solid motor retro-thruster pack in favor of a dual-function tractor-tower system that provides the function of both the launch-escape system and retrorocket pack. Additionally, the reserve parachute is replaced with a lighter-weight individual pilot parachute system.

A single-use NERVA nuclear rocket motor provides for light-weight and space-efficient orbital maneuvering operations, and hydrogen propellant tanks are clustered such to provide for maximal radiation shielding, allowing the dedicated lead shield to be smaller and lighter. Shielding is also provided through the use of molten-core reactor, with lead incorporated into the liquefied nuclear fuel for combination neutron mediation and shielding for a lighter overall weight. The small-diameter motor tube accommodates

Figure 2: Mercury Boost Configuration

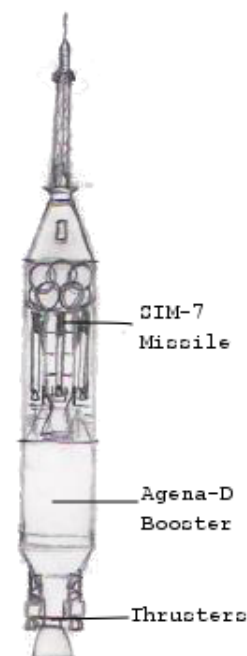

four SIM-7 SparrowFire medium-range missiles for offensive capability at any orbit on axially mounted canting launch rails.

Key to the Mercury B's flexible mission profile is the use of a stock RM-81 Agena D chemical upper-stage (Figure 2), with restartable rocket motor and twin gimballed thrusters. This allows for orbital maneuvering and engagement of multiple targets in low-Earth orbit, followed by a long burn of the nuclear motor for final interception and deorbit burn, or for a single full burn of the Agena stage in sequence with a full burn of the nuclear motor towards the moon. The latter profile was conceived for use in escort missions of Apollo Lunar Conveyor cargo and personnel, with pilots on wake-up alert outside of Soviet-patrol orbits, though the exceedingly narrow mission margins, lack of a proper docking adaptor for crew rotations and the resulting strenuous week-long missions, combined with the high cost of single-use nuclear space operations, has curtailed operation to only the highest priority missions.

## GEMINI AND DERIVATIVES

The exceedingly versatile Gemini, with its light weight, pilot-friendliness, built-in soft-docking adapter and lunar-transit capability with off-the-shelf components have built it into the backbone of American strategic manned space operations. Gemini hardware is prolific in a variety of applications, including the servicing and resupply of lunar and low-Earth orbit space stations, the recovery and management of nuclear space equipment, and cargo and personnel transit to and from the Earth.

Presented here are common Gemini-derived hardware in current use by the USAF. Into the 1980s, the air force plans to supplant or replace the direct-launch Mercury platform for space interception with a Gemini-based patrol model similar to that employed by the Soviet Union.

### GEMINI-CENTAUR "ORBITAL TRUCK"

Figure 3: Gemini-Centaur

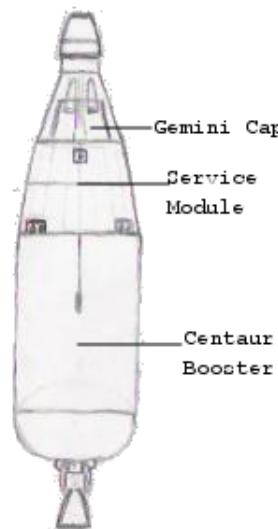

Mating of the stock Centaur upper-stage for Titan-series rockets with a mass-production Gemini spacecraft provides for single-launch translunar access with entirely off-the-shelf hardware (Figure 3), while maintaining the low weight, soft-docking and orbital maneuvering capabilities that defined the original Gemini. Current production-run Gemini capsules pioneered the integration between aircraft and spacecraft systems that have enabled the rapid American proliferation of space. Furthermore, piloted runway landing through the use of a collapsible parasail-wing assists in the rapid adaption of aircraft pilots to space vehicles.

The Centaur upper-stage allows for basic access to lunar space, and Von Braun station accommodates pressure-sealed contact

adaption for up to four Gemini-type capsules in the soft-dock-only configuration. The on-orbit storage capabilities of the basic capsule and on-orbit refueling capacity built into current-production of Centaurs are thereafter critical importance to the use of the Gemini in lunar space, where it serves numerous roles in the maintenance of American lunar interests and can remain operational for months on end.

### GEMINI-FERRY

This is a light transport and utility variation (Figure 4) built by addition of a pressurized cargo section equipped with rear-mounted Apollo-type

docking probe. The cargo block is accessible by the tunnel and rear-hatch in the stock Gemini and allows for time-critical delivery of particular crew and cargo to Von Braun Station around the moon. This vehicle has been used as a VIP transport on more than occasion. With mission profiles centered on low-Earth orbit holdings, namely maintenance of lunar conveyor fueling and resupply stations, the Gemini-Ferry can also be purposed as an airlock or waste disposable container.

The pressurized docking adapter makes this spacecraft attractive as rescue vehicle for stranded spacecraft, though with no immediate return capability, procedure would leave the crew entirely dependent on American transportation infrastructure for Earth-return.

The low Lunar gravity greatly enhances the orbital maneuvering capacity of this vehicle which, combined with the added utility of the cargo block and airlock, makes this an attractive vehicle for operations in Lunar space. The Gemini-Ferry has been considered as an "LM Tender" for certain deployment schemes of Lunar-Surface infrastructure. With the centralization of all Lunar-Surface transit to Von Braun station, this was deemed unnecessary, but one or two such vehicles are typically docked to the station for retrieving inbound lunar cargo or crews with engine or maneuvering troubles.

### GEMINI-TRANSPORT TITAN

The fifteen-foot diameter large-cargo block Gemini Transport (Figure 5) features the largest pressurized cargo block of any mass-production-type Gemini spacecraft. Intended for use with the Apollo Lunar-Conveyor System, the total mass of the system is comparable with the 25-foot diameter cargo-blocks employed by that system for Lunar transportation. Combined

Figure 4: Gemini-Ferry

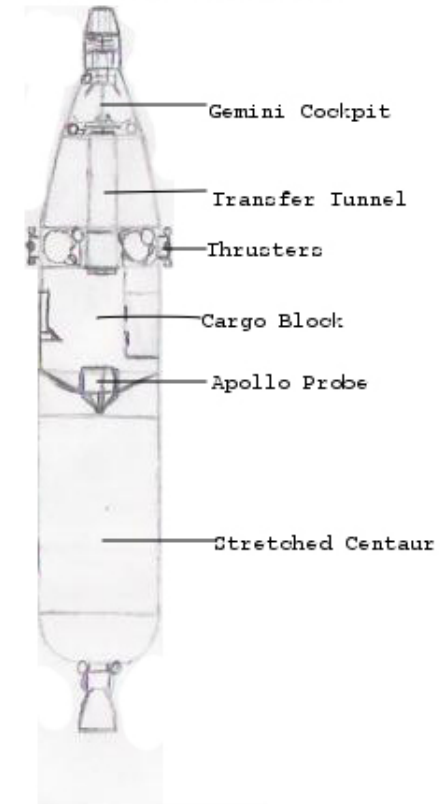

with its large cargo return capability and launch atop the same Titan IIIM rocket with seven-segment solid boosters that allow for lunar operations with ten-foot diameter Gemini-derived spacecraft, this has ensured fully half of US transit flights to the moon involve this variant of Gemini-Transport.

The stretched re-entry module, headed by a stock Gemini capsule as the craft's cockpit, is also capable of piloted runway landing through an extended version of the basic Gemini parasail system. Furnishable with up to ten seats or two metric tons of cargo, the stretched re-entry vehicle can be incorporated onto a number of different maneuvering systems, though commonality centers on the fifteen-foot diameter retro-fire and deorbit pack and its pressurized access tunnel. A maneuvering segment, through which the access tunnel traverses and with which the cargo component shares its outer pressure shell directly abuts the retro pack. It is equipped with sufficient thruster and fuel systems for extensive orbital maneuvering capability. Several high-output fuel cells provide for electrical power.

In addition to the large pressurized bulkhead section, the cargo block features an additional pilot station for docking operations, a rear-mounted tapering airlock inset into the Titan upper-stage adapter segment, and terminates in an Apollo-type docking probe. While not typically configured for spacecraft refueling operations, paired plumbing lines for fuel and oxidizer or monopropellant are standard to accommodate pump and tank segments.

Figure 5: Gemini-Transport Titan

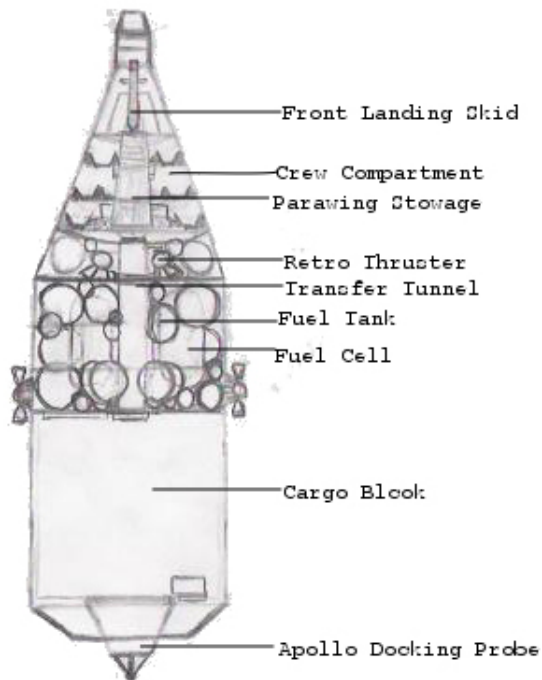

## GEMINI-TRANSPORT SATURN

The twenty-five-foot diameter variant of the transport Gemini (Figure 6) is the largest direct-launch lunar spacecraft in use. Mating the common transport Gemini stretched re-entry and retrofire modules with a further extended cone to twenty-five-foot diameter, tapering back into a similar conical airlock segment with Apollo docking probe. Use of a standard S-IVB upper-stage allows the twelve-person spacecraft with an appreciable cargo volume to be sent directly to the moon by Saturn V launch. Low-earth

orbit applications use a smaller Saturn IB with the S-IVB upper stage.

The internal arrangement of the stretched-cone resembles the Titan-launch variant, albeit with a more compact maneuvering segment given the wider diameter and a smaller (though internally similar) cargo block layout. Various studies have attempted to adapt this to a large-crew lunar landing shuttle but have so far been unsuccessful in replacing the low-capacity but highly prolific variants of the basic Lunar Module for surface supply and personnel landing.

US Federal budgeting typically accounts for only a certain amount of Lunar Conveyor flights per year, making this an option for crew rotation where heavy cargo allocation is required in a fiscal year. Where this vehicle is most typically deployed is for crew rotation in low-earth orbit, where its extensive orbital maneuvering capability and spacious crew capacity allow for rotation of multiple crews in multiple spacecraft in the same mission.

Figure 6: Gemini-Transport Saturn

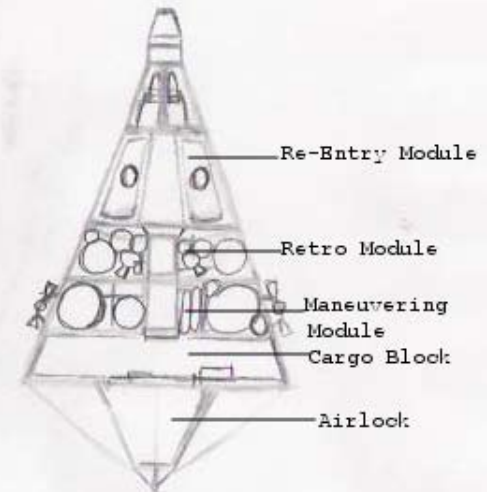

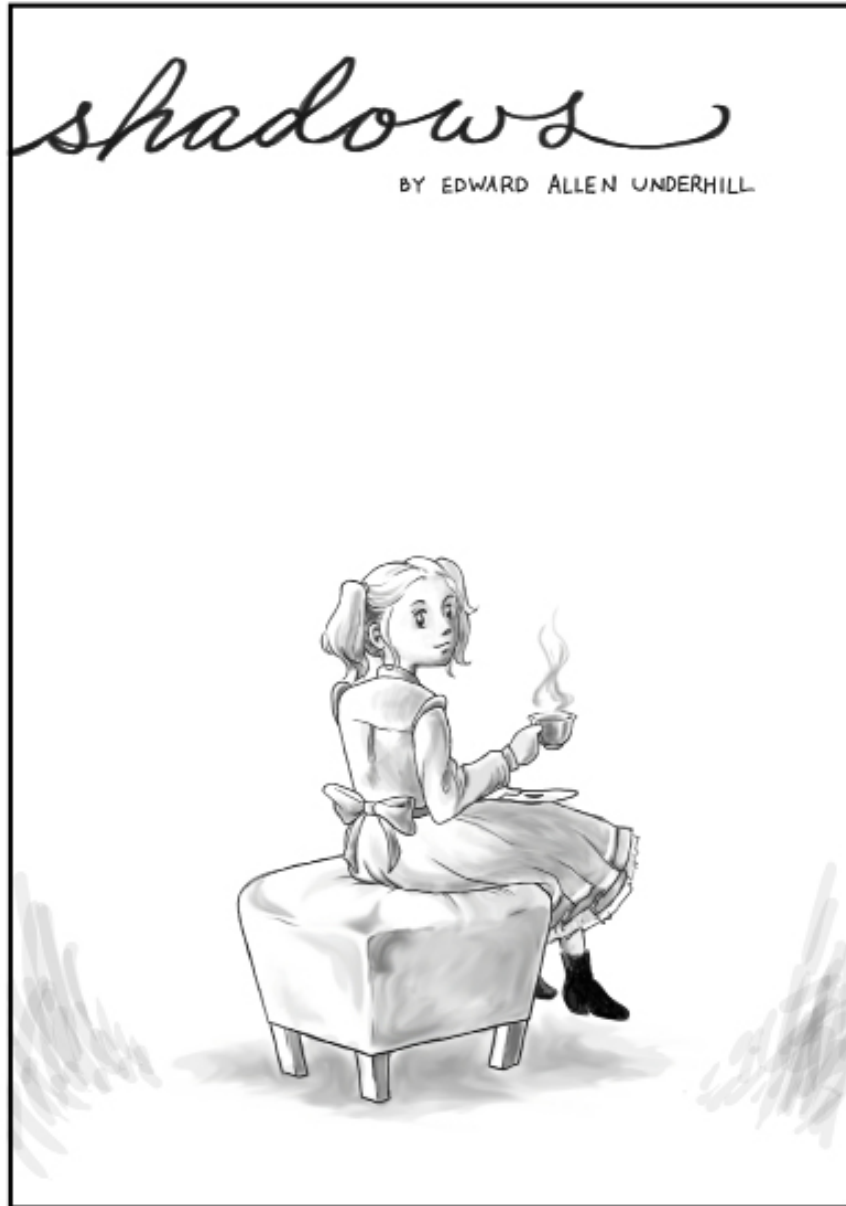

by EJ Landsman

## Shadows

by Edward Allen Underhill

Part Six: Ties

*Dublin, Ireland*  
1886

**I**t was raining on the evening that Nettie couldn't find Amos. Thunder rumbled in the distance. Every now and then lightning streaked across the horizon. Even in cat form she let out a sigh when she leapt up on the windowsill and saw the rain outside. She hated getting wet, especially as a cat.

She looked around. There was no one in sight. All the nurses were busy; in an hour they would worry, when they tucked all the children into bed and couldn't find Amos.

With a soft *pop*, Nettie changed into human form and rooted around in the front closet. She found a shawl that probably belonged to one of the nurses and pulled it around her shoulders. Then she pushed open the door and went outside.

She found Amos sitting under the apple trees in one corner of the garden with his knees pulled up to his chin and his arms wrapped around them. He wasn't wearing a jacket — only his sweater — and his hair was matted flat from the rain.

"Amo-*chan*," she said quietly.

He started.

"It's only me." She ducked underneath the apple trees and sat down beside him. "What are you doing out here in this weather? You'll catch cold, and the nurses will look for you soon."

He said nothing, but a tear tipped over his eyelid. Halfway down his cheek it turned red.

Nettie reached out. "What happened?" She dabbed at the scratch on his cheekbone with one sleeve.

He pulled away.

"Amos . . ."

\* This piece is the sixth in an eight part series. Please read the last five issues of *Spiral* for the other parts.

“People.” It was barely a whisper. “I’m not scared of demons anymore.”

Nettie lowered her hand.

“People are . . . people are . . .”

Nettie’s frown vanished. “Oh,” she murmured. She looked over her shoulder, through the apple trees, at the towering stone church beyond the picket fence. “It’s all right. I’ll take you inside, and you can go to bed. You don’t need to see any people at all. He won’t be there.”

She stood up, reaching down for his hands. They were so small—he was still so much smaller than all the other children, too small for nine years old.

She pulled him to his feet. “I’ll carry you.”

“Do you think,” he whispered, “that when I’m old like you, things will be different?”

She smiled. “I’m not old, silly.” She turned around and crouched down. He put his arms around her neck and she hoisted him onto her back. “And I’m sure they will,” she said, ducking out from under the apple trees. “You’ve got me to help, after all.”

Amos turned and looked at Sirius.

Sirius silently looked back at him.

“What happened?” Emmeline asked, staring at the wall where the painting had been.

Nettie reached out and pulled her close. “What are you doing, Siri-*jan*? You knew Amos was standing there—”

“Nettie—” Amos began.

Nettie whirled to face him. “He could have killed you!”

Emmeline’s wide blue eyes turned to Sirius.

“It’s nothing,” Amos said, looking away. “This demon is powerful. It could easily influence Sirius without him realizing, with his heightened daemon senses.” His voice was shaking.

Sirius looked away from Emmeline. His fist closed, trying to shut out the feel of her warm small hand in it.

Amos pulled the chain out of his pocket again. “We have to move quickly, before this ghost does,” he said, putting the chain over his head. The pentacle hung against his chest. “I’m pretty sure she went this way. Sirius, if you’ll follow me please . . .”

He crossed the room and went out, passing close to Sirius—so close that his sweater brushed Sirius’s jacket sleeve.

Sirius glanced up at Nettie and Emmeline, briefly, and then he turned and followed Amos.

The two of them went farther down the hall, Amos pausing at each door

to look into the room before continuing on. Sirius followed at a distance, never stopping, only slowing his pace until Amos started moving again.

It meant that when they finally reached the end of the hall, Sirius was nearly beside him.

Amos reached out and pushed open the last door on the hallway.

Beyond was a bedroom. In its center stood an elegant four-poster bed, draped in thin silk hangings. In one corner was a writing desk; in another was a wardrobe . . .

The hangings around the four-poster billowed. Amos’s eyes went to the window. It was closed.

A soft jingling sound made him start. He looked down at his wrist.

“Sirius—” he began, and staggered.

The silk hangings blew apart, and a young woman floated up from between them, her long dark hair swirling around her head, her eyes glowing red in a white face. Her long white nightgown billowed up around her knees.

She wasn’t completely there. Some part of her was trapped somewhere else, because she was the faintest bit transparent.

She floated up to the top of the bed, until she could have perched on one of the posts if she wanted to.

“So you’ve found me,” she said, and her voice wasn’t human, but deep and distorted, edged with hiss. “I guess the hide-and-seek is over.”

Amos stumbled. His fingers curled into his sweater, over the pentacle.

She was strong, because . . . because . . .

This was familiar. This energy—her energy—because he’d felt it before . . .

“You know”—the demon tilted her head—“he begged me not to leave him. He couldn’t let go. He begged and begged.”

*It’s all right, sweetheart. You’ll be fine without me.*

“I tried to tell him to let me go.” Her wide smile faded, and her eyes suddenly seemed to glitter. “I tried to tell him it would be easier, if he could just let me go . . .”

*People will come. They’ll take you to a safe place—a church—and you’ll be all right.*

“But he couldn’t.” Her gaze turned inward. “He said he couldn’t live alone. And now . . . now that I’m still here . . . he can’t live with me.”

*He tried to tell her that he was afraid of churches—they were so large and cold and dark, full of things he didn’t understand—but he couldn’t, because she was already pulling him close . . .*

*He could feel her heartbeat.*

“And all he could say,” she murmured, “was . . .”

Amos whispered, “Please don’t leave me.”

The glitter disappeared from her eyes. She threw back her head and shrieked, a deafening, inhuman sound that made the windows rattle and the house moan in sympathy.

Another flash seared through Amos's chest. He couldn't breathe.

She held out her arms, rising higher, until her swirling hair brushed the high ceiling. Wind rushed around her in a whirling tornado, picking up the dust from the room and turning the air gray. The curtains flapped madly. A mirror beside the wardrobe blew out in a shower of glass.

Sirius waded through the wind and the noise.

The walls of the house seemed to bend inward, curving in on them.

He reached Amos, and wrapped his arms tightly around him.

Through the screaming, moaning, rushing of wind, and rushing of voices in his head, Amos heard Sirius's voice close to his ear.

"I won't."

Amos opened his eyes.

The blinding pain faded and through it he could suddenly feel Sirius's hands against his chest.

His fingers closed around the pentacle, on its chain around his neck. He brought it up, between his hands, and closed his eyes.

Black feathers swirled into the wind.

Sirius's wings were suddenly out, extended around them, blocking out everything but the ghost in front of them.

Amos whispered a word.

White sparkles rose in the air. From the hem of her dress they slowly rose, glimmering brighter and brighter, like hundreds of icy fireflies, until she was lost in them and all the shadows in the room washed away.

Amos could breathe again. He whispered one more word.

The scream faded. The sparkles faded. Shadows crept back into the edges of the room.

But when Amos opened his eyes and looked up, there was still a bright light surrounding the figure of the young woman floating above them. Her rich dark hair tumbled around her shoulders. Her eyes shimmered.

"Thank you," she whispered.

And then, with one last smile, she disappeared in a rising white mist.

Before long, the mist vanished, too, and all that was left was a stray sparkle here and there, and the silent room, strewn with broken glass.

Sirius lingered on the porch when they arrived back at the apartment building. Nettie pushed Amos inside and toward the stairs. She wanted Emmeline to come with her, but Emmeline flatly refused. She wanted to stay with Sirius.

Nettie looked at Sirius, who was looking out at the street with his

hands in his pockets. She sighed and reluctantly consented, but said she would come back for Emmeline very soon.

Then she went upstairs to the flat with Amos.

As soon as they were inside, she closed the door and turned to face him. "He tried to kill you."

Amos ran a hand over his eyes. "You saw how much of a grip that ghost had on the house. It's a miracle no one was hurt before we got there. She was probably affecting Sirius."

"You're making an excuse for him?"

"He's a powerful daemon, Nettie. He was probably more affected than the rest of us because of that."

"Because it was bringing out his darker side. He isn't safe. Didn't you see it?"

"When he changed form?" Amos put a hand on the table to steady himself. "Yes. I saw it."

"That's his true form," Nettie said quietly. "Before he was sealed, that's what he looked like all the time. He's one of the Old Ones, one of the most ancient and powerful daemons. Ones like him don't even exist anymore. Long ago they used to live to hundreds of years, but they dwindled with the fading of magic in the world, and most of them were hunted down and killed . . . hundreds of years ago."

"I know what he is, Nettie," Amos said sharply.

Nettie fell silent.

Amos's face was ashen—the slowly healing gash on his forehead stood starker than ever. "I know sometimes you think I'm . . . that I don't know what I'm dealing with. Because you're so much older than me—because for the longest time you took care of me—you have to protect me. But I know what Sirius is. I've figured it out."

"Then you know you have to let him go," Nettie said.

Amos opened his mouth.

Emmeline banged through the front door.

Nettie and Amos both jumped.

"Emmie-*chan*!" Nettie turned around. "What are you doing?"

"Sirius!" Emmeline pointed behind her. "He said he was going, and he wouldn't let me stop him!"

Nettie opened her mouth, but Amos had already pushed past her for the door. "Wait!" she cried, making a grab for his sleeve.

He skirted Emmeline and disappeared out the door into the hall.

"Oh, no." Nettie grabbed her skirts and ran after him.

Amos pounded down the stairs, his fingertips gliding along the railing. Nettie was calling behind him, but he barely heard her. He reached the first floor and slammed through the door, out onto the porch and down into the

street.

It was still raining.

Sirius was standing in it, on the rooftop of a building across the street.

His wings were out.

“Sirius!” Amos yelled.

Sirius looked back, for a moment. His long black hair clung to his face. Rain trickled from the ends of his wings.

Then he turned away. His wings unfolded, spattering water. He stepped off the rooftop, and his wings beat, carrying him into the air.

“Wait!” Amos started running down the street after him.

“Amo-*chan*, no!” Nettie had caught up with him. She grabbed him from behind and dug her heels in.

“Sirius!” Amos tried to pull away, but she wouldn’t let go.

It didn’t matter anyway. Before long, Sirius was swallowed by the clouds.

Emmeline finally arrived on the porch. She was running so fast that she had to collide with one of the porch posts to stop herself. When she recovered and looked up, she hugged the post tighter.

Nettie still had her arms tightly around Amos, but he wasn’t fighting her anymore. His hands hung loose at his sides, his head was bent, and both of them were soaking from the rain.

Eventually, there was nothing for it. They had to go shopping.

They hadn’t really had enough food to begin with. And even though Amos barely touched anything Nettie cooked, she felt she had to keep on cooking, because perhaps sometime she might make something that would suddenly get him interested in food again.

“He’s so sad,” Emmeline said quietly, when she brought a cup of tea into the kitchen from Amos’s closet office. It was still nearly full.

“He’s just . . .” Nettie didn’t know what to say. “It’s just that—”

“He misses Sirius.”

Nettie stared at Emmeline in surprise. Emmeline tilted her head, curls bobbing, and smiled. “It would be nice if, sometime, they admitted it to each other, wouldn’t it?”

Nettie looked at her. Then she laughed a little, sadly. “Wouldn’t it.”

Besides shopping, Nettie thought perhaps just getting outside might cheer Amos up a little. Of course, he vehemently hated nature, but there wasn’t terribly much nature in London to begin with, and he had always taken walks when he was frustrated and restless before.

So, when Sirius had been gone for nearly a week, Nettie and Emmeline put on their jackets and mittens and dragged Amos from his office. “Put on a shirt underneath that sweater at the very least,” said Nettie, shoving him

into his bedroom.

When they went outside, it had finally stopped raining, but the sky was still overcast and threatening.

“Did you bring a shopping list, Nettie?” Emmeline asked excitedly as they went down the street. “May I see, may I see?”

Amos followed a step or two behind them, his hands tucked into his pockets. He’d put on his extra shirt underneath his sweater, which was lucky, since it had turned chilly and windy outside. Gusts of wind kept rushing up behind him, blowing his bangs into his eyes, nudging him forward a little faster, as if they wanted to keep him walking.

Nettie let Emmeline drag her into a dress shop . . . and tugged Amos along behind her. As far as necessity went, of course, a dress shop was last on the list—they didn’t have enough money to buy any of these dresses anyway—but Amos knew Nettie was indulging Emmeline because she wanted to cheer him up.

But looking around the dress shop, he only thought of the first time he had met Sirius, in some village that he didn’t even remember the name of, where they had gone looking for a suit for Sirius.

None of the dresses around him were suits, because they were all dresses—in fact, there didn’t seem to be any suits at all—but somehow the shop only made the ache inside him run a little deeper.

He didn’t say anything. He only nodded and smiled when Emmeline eagerly pointed to the dress she wanted when she grew up to be taller.

He didn’t have the heart, or the energy, to tell Nettie that he couldn’t be cheered up. She was trying so hard, after all. It would only hurt her feelings.

They finally wandered out of the dress shop. For a while, they stood outside on the street corner, while Emmeline puckered her face reading the shopping list aloud to remind Nettie what they needed. Then Nettie—who had quite clearly known all along what they needed without Emmeline’s reminding—led them off in the direction of the general store.

Amos paused on the threshold. “Why don’t you go ahead?” he said.

Nettie looked back at him. “You could hold a shopping bag,” she said a little helplessly.

He recognized her helpless look. He’d seen it before, many times, when he had been much younger. It was the expression she always wore when she came to find him—wherever he was hiding—but she thought he never noticed.

He smiled. “It’s all right,” he said. “I’d just like to stay out in the air a while.”

Nettie sighed. The smile was too faint—too tired and too faded—but she couldn’t tell him that. “We’ll be out soon,” she said.

He nodded.

She hesitated. Then she reached down and squeezed his hand, briefly, before she turned and disappeared into the store after Emmeline.

Amos tucked his hands in his pockets and turned away.

He was staring at the ground when he stepped out into the street, so he ran straight into someone.

"Excuse me!" he said, looking up.

The old man in front of him regained his balance and clapped his hand to his head to keep his cloth hat from sliding off. "Oh, it's all right," he said, with a wide, toothless grin. "You were deep in thought." He peered at Amos closely. "Ah, aren't you that Mr. Christopher fellow? Mr. Amos Christopher?"

Amos blinked in surprise. "Er . . . yes . . . but it's Amos, actually . . ."

"I've read your articles!" the old man exclaimed. "And I've seen you about. I work for Mrs. Maloney on occasion, see. Mostly little repairs that she needs done about the house."

"I see," Amos said with a frown. "I don't think I've seen you around before."

"Has the tall fellow still not caught up?"

Amos started. "Beg pardon?"

"Oh, the tall fellow I always see you about with. Isn't he your assistant?"

"Sirius?" Amos whispered.

"That's it! I knew Mrs. Maloney had said the name once or twice. Unusual name, isn't it? I just saw him—figured you couldn't be far away—but I guess he hasn't caught up to you yet."

Amos felt as though his stomach had dropped to his feet. "You—you saw him? Where?"

The old man blinked. "What?"

"Where did you see him? Can you tell me where he is?"

"The cemetery on the edge of town," the old man replied. "Is everything all right, then?"

"Thank you," Amos gasped.

"Well, it's no trouble—" the old man began, but Amos was already gone, running down the street.

The old man watched him. A smile curled around his lips. "No trouble at all."

Amos ran for as long as he could, dodging through the street traffic, with no thought for the muddy puddles he splashed through. But eventually, he couldn't run anymore. He finally stopped, leaning against the side of a building, gasping for breath. Then he started again, walking this time.

The cemetery was right at the edge of town. Amos walked under the

wrought iron archway, through the open gate, following the wide dirt path between the fields of graves on either side. Some of them were small, worn, the names all but erased from the wind and the rain. Others were tall, stone cross pinnacles reaching for the sky.

*"Did you see the little brat had the audacity to come to her funeral? Such nerve."*

*"Well, Alyce was quite fond of the boy, you know."*

*"But a brat like him? With a history like he's got, how do we know he didn't kill her?"*

Amos paused. Next to him was a small, modest gravestone. At its base, someone had put a bouquet of new flowers.

*"It was familiar. Is that why it hurt?"*

Amos blinked and jerked out of his thoughts. "Sirius," he whispered.

A cold wind rustled dead papery leaves around his feet. The air felt so different now. Deep into November, the autumn tang had gone and the air was only cold, empty, and damp.

He shivered and folded his arms across his chest, looking around. He started walking again, wandering farther down the path, deeper into the cemetery.

There were so many graves. Sirius could be anywhere.

There were too many graves.

"Sirius!" Amos called. His own voice echoed back to him, thin and dead, just like everything else.

Up ahead was a mausoleum, a low, squat building, made of gray stone and covered in lichen.

Standing in front of it was a tall, dark figure.

"Sirius?" Amos picked up his pace again. He was too tired to run, but he tried anyway. "Sirius!"

The figure turned, and as it did, the dark hair and the dark suit faded. The wings disappeared. They rustled away with the wind, replaced by long, tumbling pale hair and a long, flowing white dress.

Amos stumbled to a stop.

"Absence makes the heart grow fonder?" The Sorceress smiled. "How have you been, my dear Mr. Christopher?"

Amos reached a shaking hand up to his neck, fumbling for the silver chain.

"None of that, please." The Sorceress held out a slender white hand.

Amos felt the chain around his neck break. The pentacle soared through the air away from him. The Sorceress's fingers closed around it.

"Now that I know this is where you get most of your power from . . ." She rubbed her thumb over the silver. "I think I'll have to keep this. It will be helpful. It has your memories attached to it, doesn't it?"

"Where's Sirius?" Amos whispered.

The Sorceress looked at him. “I haven’t the faintest idea.” Her lips curled upward. “But you’re going to help me find out.”

Sirius stood on top of the church for a long time. He was standing on the very top of the cross that stabbed toward the sky—to people below, he might even have looked like a decorative angel, if they hadn’t tried to look too closely.

He lifted his hand and looked at it. It never used to be like this. It used to have claws. Always. He remembered now.

He remembered the feeling of a small soft hand, clutching his own. He remembered Emmeline’s bright blue eyes and her blonde bobbing curls. How much she loved serving tea on the fancy tea trays—sometimes he would let her make him tea even when he didn’t want any, just because it made her smile and clap her hands.

He remembered her baking with Nettie in the kitchen. Sometimes, if Emmeline begged enough, Nettie would let her kitten ears poke out for a little while, as long as there was no risk of anyone else coming in.

And then, as soon as the smell of baking wafted through the flat, Amos would come out of his office looking for a way to avoid writing his article.

A tiny drop of water landed on Sirius’s hand. He stared at it, wondering where it had come from, before he felt something warm running down his cheek. Another drop splashed beside the first.

It was the tie that was keeping him here—nothing but the magical tie—keeping him from leaving this city, and leaving Amos behind.

After all, the daemon in him, the one he’d forgotten, had found its way out and . . .

Perhaps Sirius wasn’t even his real name. Once, long ago, it had probably been different. He couldn’t remember, but it had probably been . . .

Then why did it feel like the only one? Just as real as the cross he was standing on. The only one that mattered. He had heard Amos call it, and something had broken through the Seal, broken through the quiet and the deadness. And the world outside, for all its annoyances and irritating people, had seemed so much more real and alive than anything else—even anything in the memories screaming through his head.

Sirius jerked.

He wasn’t remembered Amos calling.

He was hearing it now.

Somehow, in his mind, cutting through all the screaming and noise and rushing memories, he could hear it.

“Nettie.” Emmeline tugged on Nettie’s skirt. “It’s looking like it might rain again. Oughtn’t we to go?”

Nettie handed a few coins to the shopkeeper. “Thank you very much,” she said, picking up the bag. She looked down at Emmeline. “I suppose you’re right.” She sighed, looking through the open doorway of the shop to the street outside. “I only wanted to get Amo-*chan* out for a while—but it doesn’t seem to be helping anyway.”

“Perhaps some tea will help!” Emmeline picked up a smaller bag and started confidently toward the door. “I could make tea!”

Nettie’s shoulders slumped. “I don’t think that helps as much as you wish it did, Emmie-*chan* . . .”

They left the shop and went back into the street.

Emmeline blinked. “Nettie,” she said, “where’s Amos?”

They looked up and down the street. The crowds were starting to thin under the threatening sky, but Amos was nowhere to be seen.

“Oh, no,” Nettie whispered.

Emmeline looked up at her. “You don’t think he went looking for Sirius, do you?”

“Emmie-*chan*, do you think you could carry this bag, too?” Nettie held out the other shopping bag.

“We didn’t buy much.” Emmeline took it from her. “I can carry it. But what are *you* going to do?”

Nettie grasped her shoulders and steered her quickly between two shops, around to the back of the buildings. “I’m going to try to find Amos,” she said quickly. “You just wait for me in front of that store, all right? Don’t go anywhere.”

Emmeline’s eyes widened. “No! I’m going with you!”

“Emmie, you can’t. You need to wait here for me, all right?”

“No!” Emmeline stomped her foot. “I’m going with you!”

“Your aunt will worry about you!”

“But *I’m* worried about Amos and Sirius!” Tears welled in Emmeline’s big blue eyes. She looked away, wiping her face with her hands. “I know it’s not real, because Mummy and Daddy are gone, but . . . but . . .” She looked up at Nettie. “But they’re my big brothers, and I want them back so we can be happy again.”

“Nettie?”

She gave Amos another hoist. “Yes?”

“You’re kind of like my big sister, right?” It was a barely a whisper, just next to her ear.

She paused on the stone steps, even though it was still raining.

“That’s right,” she said. “I’m your magical big sister.”

Nettie knelt down, wiping away Emmeline’s tears with the corner of her shawl. “We’ll find them,” she said. “Together, all right?”

Emmeline nodded.

Nettie straightened up and closed her eyes. Then, with a faint *pop*, she turned into a medium-sized brown shaggy dog.

Emmeline blinked. "What are you doing?"

"Finding Amos," Nettie replied. She put her nose to the ground and trotted back around the building.

Emmeline grabbed up the two small shopping bags and hastily followed her.

Nettie paused in the street, sniffing around Emmeline in a circle. Then her head came up, her lopsided ears perked forward, and she started trotting down the street.

"That way's the cemetery," Emmeline said, hurrying to catch up.

Nettie didn't say anything, but she nodded her shaggy dog head, just barely.

---



---

## Contributors List

Emma Conner (College '13)

Kira Fath (College '13)

Jeremy Ledgister (College '10)

Julianne M. Lopresto (College '12)

EJ Landsman (College '09)

Ben Tobin (College '12)

Mike Rauscher (College '11)

Julia Rosenfeld (College '11)

Edward Allen Underhill (Conservatory '09)

Emily Wilson (College '13)

---



---

## Staff List

***Editor-in-Chief:***

Bryn A. McDonald

***Artmaster:***

Jeff Zahratka

***Prosemaster:***

Alyssa Zullinger

***Rimemaster:***

Julia Rosenfeld

***Senior Editorial Staff:***

Sam Conroy

Sophie Dresser

Daniel Dudley

Julianne Lopresto

Abby Mansfield

Sam Power

***Supporting Editorial Staff:***

Brittany Brahn

Justin Murphy-Mancini

Daniella Sanchez

Elsbeth Saylor

Jennifer Sherman

***Copy-Editor:***

Julianne Lopresto

***Webmaster:***

Stephen Burrows

***Publicity Manager:***

Abby Mansfield

***Faculty Advisor:***

Taylor Allen

For electronic copies of previous issues and for more information on submitting, please visit our website:

<http://www.oberlin.edu/stupub/spiral/>

spiral@oberlin.edu  
OR  
Wilder Box 08

---

Upcoming Deadlines:

Feb. 28th at 11:59 pm

(Volume 3, Issue 1: Winter 2010)

Apr. 28th at 11:59 pm

(Volume 3, Issue 2: Spring 2010)

---

Have erotica?

We're trying to gather enough submissions for an entire erotic issue of *Spiral*!

Submit your erotic material by

February 28th at 11:59 pm.

*\*We accept pseudonyms,  
but please email from your oberlin email so that we know you are a student.*