

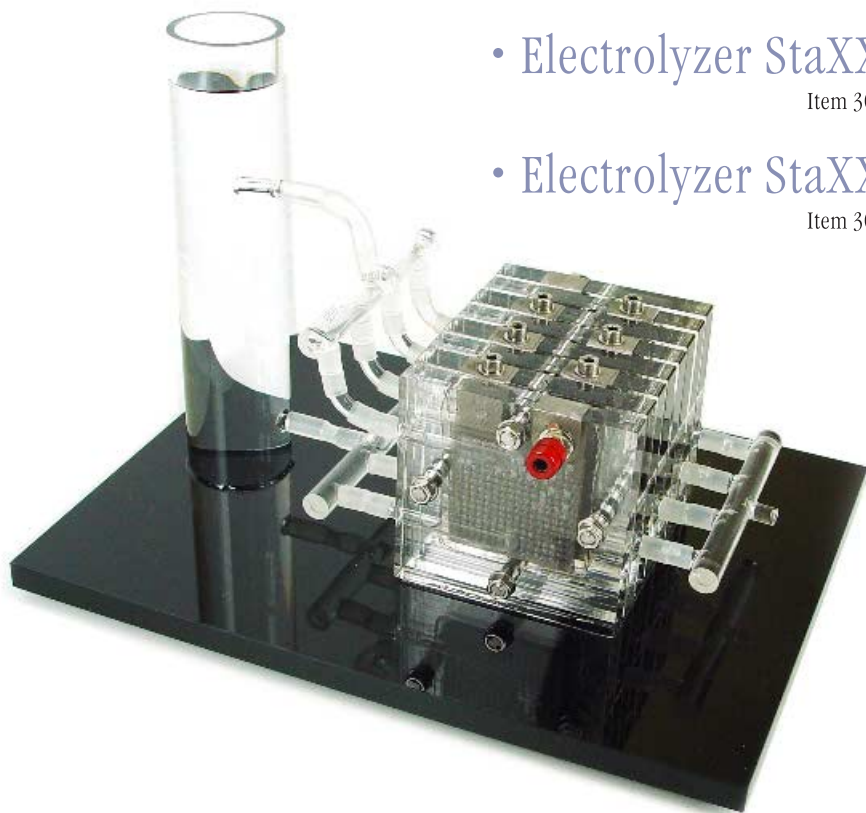

Operating Instructions

h-tec



- Electrolyzer StaXX 7

Item 3017

- Electrolyzer StaXX 2

Item 3011

Fuel Cell

h-tec
Wasserstoff-Energie-Systeme GmbH
Hydrogen Energy Systems

Lindenstrasse 48a
23558 Luebeck
Germany

Phone	+49 (0) 451-49 89 5-0
Fax	+49 (0) 451-49 89 5-15
e-mail	info@h-tec.com
website	www.h-tec.com

Introduction and Intended Use

The growing significance of PEM electrolyzers mirrors the development of fuel cells. Electrolyzers generate the hydrogen required by fuel cells from water in an environmentally conscious manner. The electrical energy required for this purpose can be gained from renewable sources such as solar cells, wind farms or hydroelectric plants.

Water reacts in the electrolyzer under the influence of electrical energy according to the following formula: $2\text{H}_2\text{O} \rightarrow 2\text{H}_2 + \text{O}_2$. This process takes place in the MEA (membrane electrode assembly). The MEA consists of the cathode, the anode, and a special polymer membrane (PEM) which is permeable to protons but which presents a barrier to electrons.

Your h-tec electrolyzer functions on the PEM principle. The gases produced can be collected in storage tanks (h-tec Storage 1 or Storage 80). The energy

stored in chemical form in the gases can be converted back to electrical energy in a fuel cell as and when required.

The equipment has been developed for teaching and demonstration purposes only.

Any other use is prohibited.

Danger!

The hydrogen (H_2) and oxygen (O_2) produced represent a source of danger if handled improperly. In order to avoid any risks you **must** follow the General Safety Precautions when working with the electrolyzer.

h-tec
Hydrogen Energy Systems



wishes you many enjoyable hours learning about this technology with the electrolyzer.

- The system is intended for teaching and demonstration purposes in schools, universities, institutions and companies only.
- It may only be set up and operated by a competent person.
- Read the Operating Instructions before setting up the electrolyzer. Follow them during use and keep them readily available for reference.
- Wear protective goggles.
- The system is not a toy. Operate the electrolyzer and keep it and the gases produced out of the reach of small children.
- Unless specified otherwise, do not short-circuit or reverse the polarity of the terminals.
- Do not operate the system empty. Always ensure that it contains sufficient water (between the water level marks).
- Remove inflammable gases, vapours and liquids from the vicinity of fuel cells and electrolyzers. The catalysts contained in the system can trigger spontaneous combustion.
- Hydrogen and oxygen may escape from the system. To prevent the gases collecting and forming explosive mixtures only use the system in well-ventilated rooms.
- Never operate the system in a display case, as escaping hydrogen



General Safety Precautions

can concentrate to form an explosive mixture.

- As the equipment is capable of producing large quantities of hydrogen, we recommend that hydrogen sensors be employed for monitoring of the ambient atmosphere. 
- Remove from the vicinity of the system anything that could ignite the hydrogen (naked flame, materials that can become charged with static electricity, substances with a catalytic action). 
- Remove from the vicinity of the system all substances that could spontaneously ignite with increased oxygen concentration.
- Do not smoke. 
- Hoses, plugs and tanks are used for pressure compensation. They must not be fixed or secured with clamps, adhesive, etc.
- Only use the gas storage tanks belonging to or supplied with the system to store gas. Never connect other alternatives.
- Only operate the system at room temperature and ambient pressure.
- Do not position any solar modules and lights in use closer than the minimum permitted distance (30 cm between h-tec solar modules and

General Safety Precautions

the h-tec Videolight, and 50 cm between them and the h-tec Spotlight, or see other manufacturers' stipulations).

- The surface of solar modules can get very hot during extended operation.

- Tell your students about any potential dangers and carefully supervise experimentation.

h-tec will not accept any responsibility for injuries or damage sustained in the event of these Safety Precautions not being followed.

Electrolyzer StaXX 2

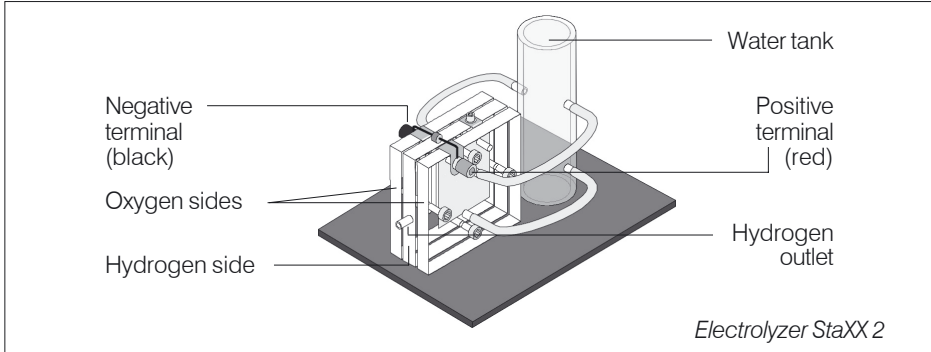

The electrolyzer StaXX 2 is a two-cell electrolysis stack. The centre of the cell houses the hydrogen side of the two individual cells. The two outer sides of

the cell have the function of supplying water and removing the oxygen produced. The two individual cells are connected electrically in series.

Electrolyzer StaXX 7

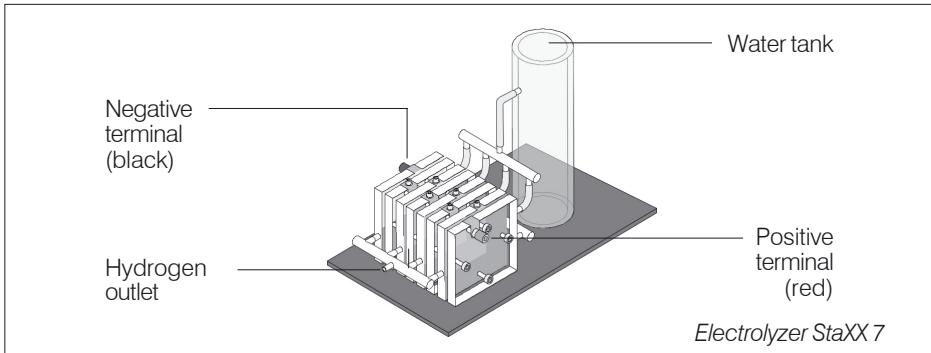

The electrolyzer StaXX 7 is a seven-cell electrolysis stack. The water required for electrolysis is supplied from below through a distribution pipe. The oxygen

generated escapes through the water tank. The hydrogen produced is collected through a connecting pipe, and is delivered to the hydrogen outlet.

Operating Instructions

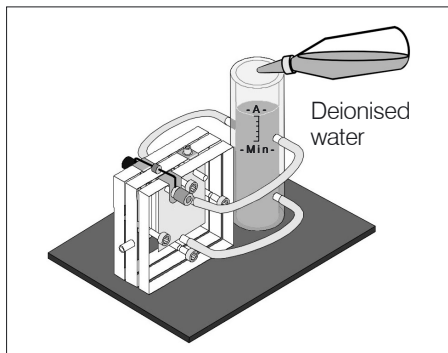

1. Read the General Safety Precautions.
2. Connect the hydrogen outlet of the electrolyzer to the hydrogen inlet of the gas storage tank (h-tec Storage 1 or Storage 80).
3. Fill the h-tec gas storage tank with distilled water up to the 0 cm³ mark,

and place the compensation tank on top of it.

4. Fill the water reservoir of the electrolyzer with deionised water up to the -A- mark.
5. Connect the power supply to the positive (red) and negative (black) terminals of the electrolyzer. Observe the maximum permissible voltage (see Technical Data). The electric current causes the water to be split into oxygen and hydrogen.

The oxygen escapes into the atmosphere; the hydrogen is collected in the gas storage tank.

6. Top up with distilled water when the water level drops below the MIN mark.

Maintenance

Although the described model of electrolyzer does not require any maintenance, you should:

- Use fresh, deionised water for each session.

Technical Data

	Electrolyzer StaXX 2	Electrolyzer StaXX 7
Item No.	3011	3017
H x W x D	140 x 180 x 120 mm	190 x 264 x 200 mm
Weight	460 g	1.480 g
Electrode area	2 cells of 16 cm ² each	7 cells of 16 cm ² each
Power	15 W at 4 V DC	50 W at 14 V DC
Permissible voltage	3.0 - 4.0 V DC	10.5 - 14.0 V DC
Permissible current	0 - 4.0 A DC	0 - 4.0 A DC
Gas production (H ₂)	65 cm ³ /min	230 cm ³ /min

